

Drum Motor Installation Manual

www.vandergraaf.com

2 Van der Graaf Court,
Brampton, ON L6T 5R6 Canada

Tel: (905) 793-8100 Fax: (905) 793-8129
Technical Support: 1 (866) 595-3292

Table of Contents

Installation Instructions	2
Electrical Connection	2
Drum Motor with Sprockets (STM) Assembly Procedure.	3
Connection Diagrams:	
Single Voltage - Three Phase.	4
Dual Voltage - Three Phase (Star/Delta)	4
Dual Voltage - Three Phase (230/460 volts)	4
Single Phase (110 volts).	5
Single Phase (220 volts)	5
Three Phase with Brake (RTM)	5
Three Phase with Clutch Brake (CBTM)	6
Connecting a Drum Motor Equipped with a Backstop (TB) Device.	7
Releasing & Engaging a Drum Motor Equipped with a Manual Release Backstop (MRB) Device	8
Oil Change Instructions	9
Oil Types	9
Drum Motor Oil Content	10
Troubleshooting	11



INSTALLING THE DRUM MOTOR:

The Drum Motor MUST be mounted horizontally, square to the conveyor frame and parallel to the idler pulley. The arrow on the shaft opposite the junction box MUST be pointing up, with no more than 30 degrees off of vertical. This will ensure that the gear reducer is properly lubricated. For special mounting arrangements, consult your Van der Graaf representative.

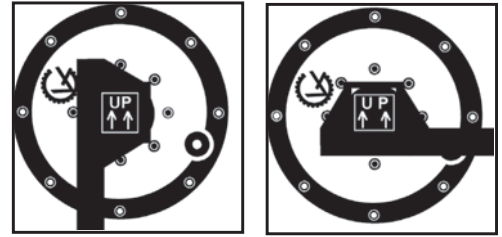

NOTE: The Drum Motor has been factory filled with the correct amount and type of oil, and does not require any additional oil. Oil change recommended at 50,000 hour intervals (see page 9).

ELECTRICAL CONNECTION:

To ensure proper electrical connection, always reference the connection diagrams provided (pages 4-6). Be sure to use qualified personnel and observe compliance with local electrical codes. If in doubt, consult your Van der Graaf representative. Ensure that the motor is being installed with the appropriate overload protection device(s), (fuse, breakers, thermal overload protection {GV-THERM}) if equipped. Reference the Drum Motor nameplate to determine allowable full load amperage.

When the motor is equipped with a backstop (TB) device, the motor must be connected electrically according to the correct rotational direction (see page 7 for complete instructions).

PRIOR TO STARTING:

1. Be sure that the Drum Motor is correctly connected and supplied with the rated voltage.
2. Check that the Drum Motor and conveyor belt are unobstructed and free to rotate.

CAUTION: Never over tension the conveyor belt as internal damage may occur.

Drum Motor with Sprockets (STM) Assembly Procedure

1. Align pin slot in Sprocket (3) to the welded pin (2) on the shell (1).
2. Slide sprocket (3) over the Drum Motor shell (1).
3. Insert Set Screw (4) in their respected holes.
4. Repeat the sequence for the balance of the Sprockets.
5. Space Sprockets on the face of the shell to match belt pockets.
6. Lock center Sprocket/s by lightly tightening set screws.

IMPORTANT NOTE:

- ▶ Observe not to deform the sprocket by excessively tightening set screws.
- ▶ Ensure that locked Sprockets in head and tail pulleys are corresponding to the same pockets in the belt.

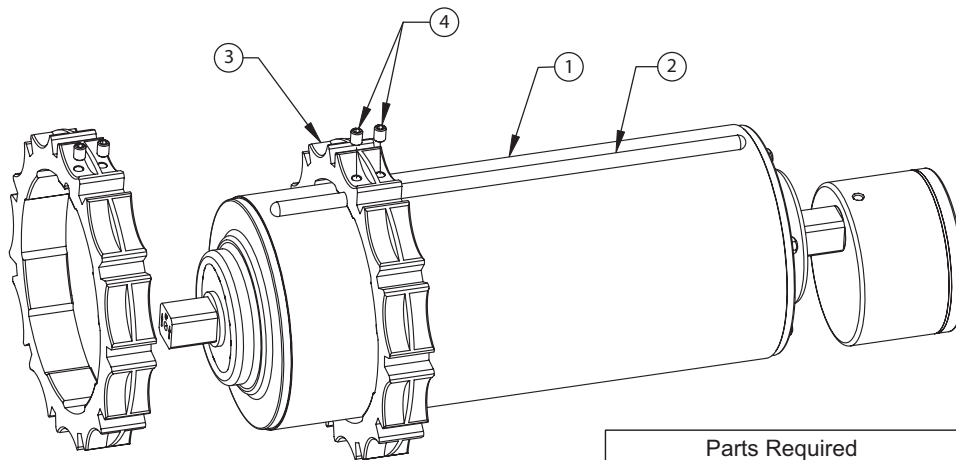

Parts Required	
Item Number	Description
1	Drum Motor Shell
2	Welded Pin
3	Sprocket
4	Set Screw (2 per Sprocket)

306 (11/2007)

Connection Diagrams

SINGLE VOLTAGE - THREE PHASE

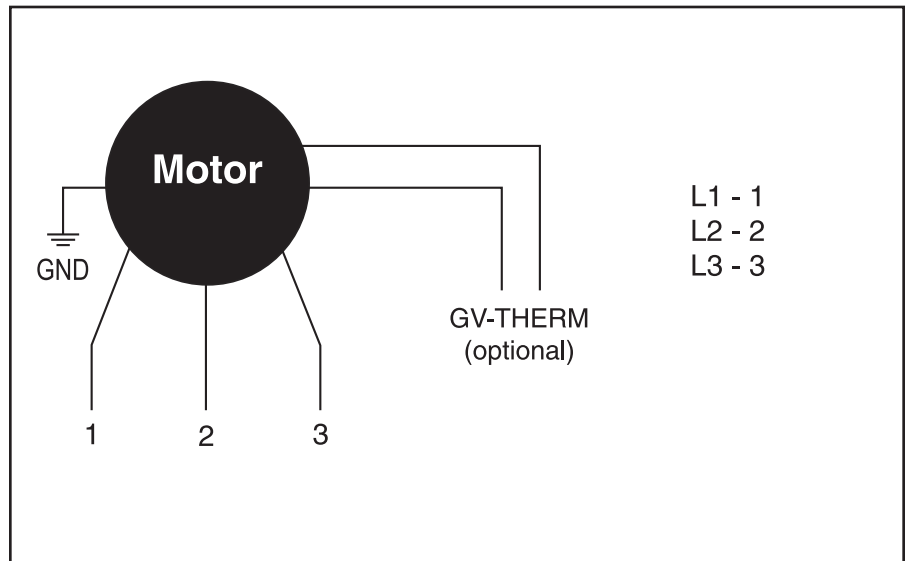

325 (12/2003)

DUAL VOLTAGE - THREE PHASE (STAR/DELTA)

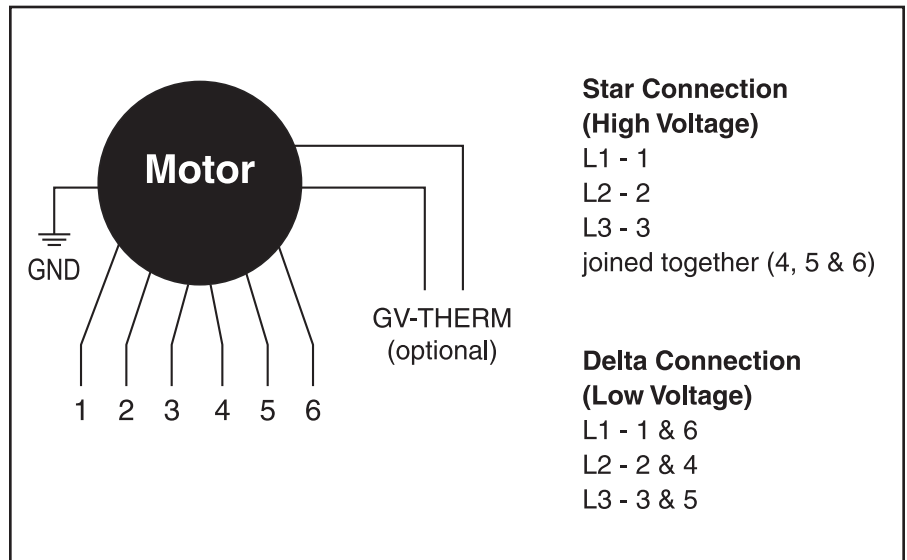

326 (12/2003)

DUAL VOLTAGE - THREE PHASE (230/460 VOLTS)

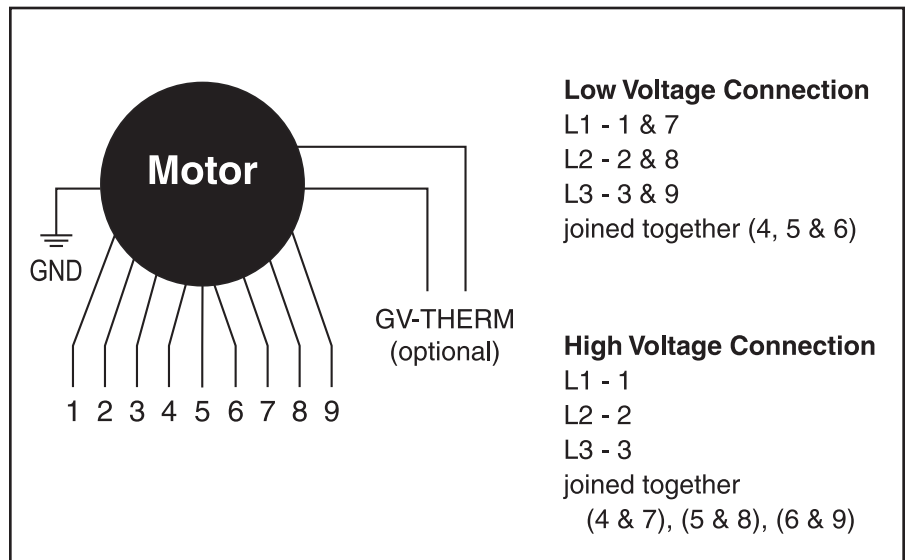

327 (12/2003)

Connection Diagrams

SINGLE PHASE (110 VOLTS)

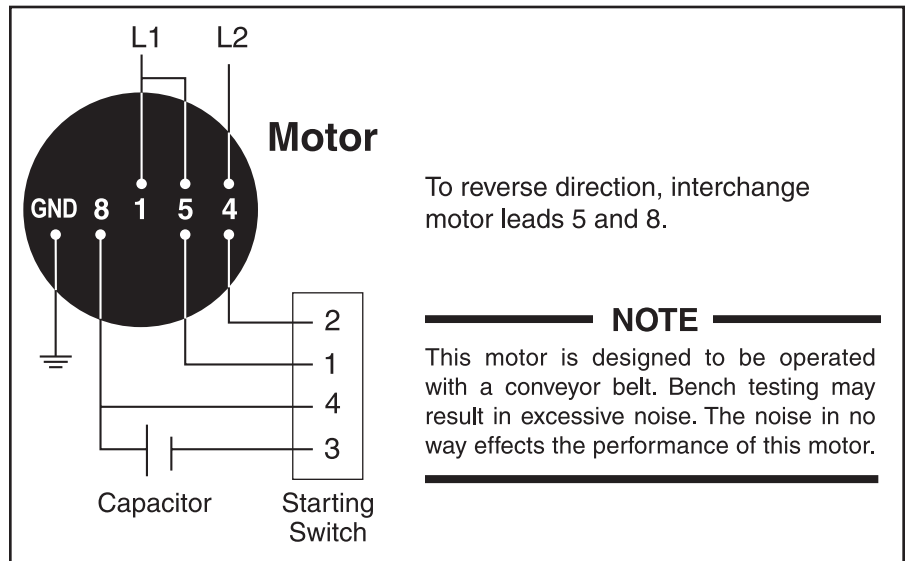

328 (12/2003)

SINGLE PHASE (220 VOLTS)

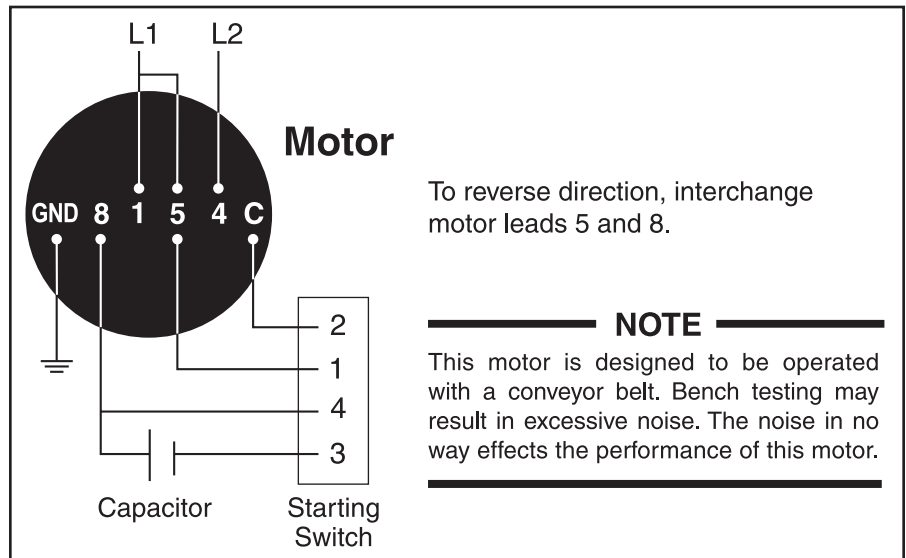

329 (12/2003)

THREE PHASE WITH BRAKE (RTM)

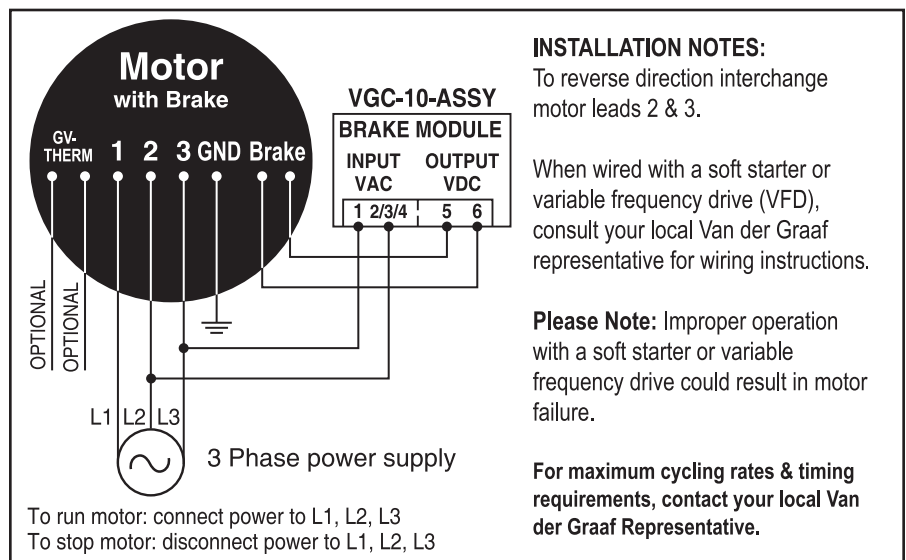

330 (04/2006)

Connection Diagrams

THREE PHASE WITH CLUTCH BRAKE (CBTM)

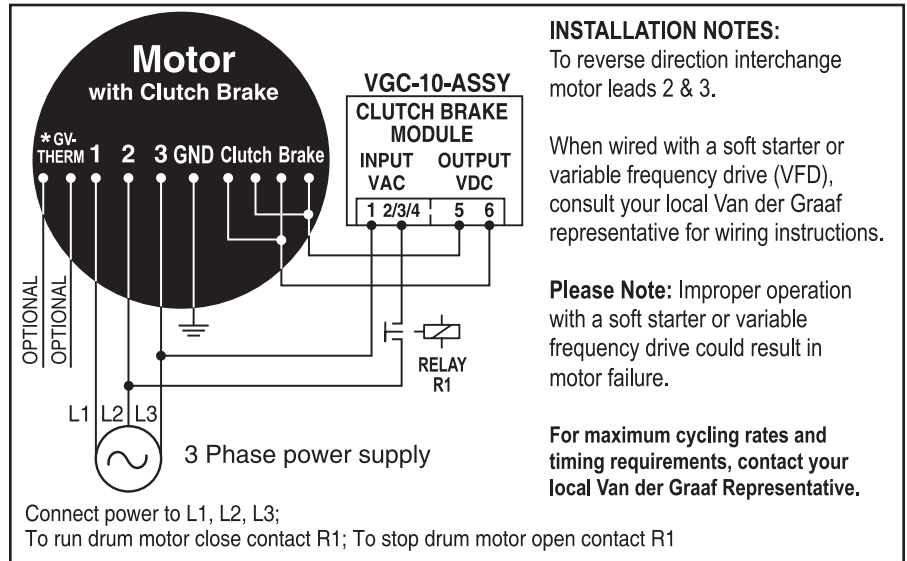

Connecting a Drum Motor Equipped with a Backstop (TB) Device

1. Look for the brass arrow on the end flange. It will indicate which direction the drum motor will rotate.
2. Mark the three incoming power supply leads with numbers L1, L2, L3. Ensure that the ground lead is properly connected to the ground.

3. Connect the incoming power supply leads:
L1 to motor lead #1
L2 to motor lead #2
L3 to motor lead #3

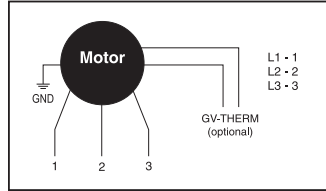

4. Turn the power to the motor ON and OFF, (no more than 0.5 seconds on the ON position). If the motor rotates then the connection is correct and you can proceed to step 5. If the motor does not rotate, interchange any of the two power supply leads.
Example: L1 to motor lead #2
L2 to motor lead #1

Turn the power ON and the motor should rotate in the correct direction. Change the markings on the incoming power supply leads to correspond with the motor leads.

Example: L2 to be changed to L1 and
L1 to be changed to L2.

Before Step 4 is complete, the motor should be running in the correct rotation and the connection should be as follows:

Power supply		Motor Leads
L1	to	1
L2	to	2
L3	to	3

When that is completed, proceed to step 5.

5. Finalize the motor connection:

Power supply		Motor Leads
L1	to	1
L2	to	2
L3	to	3

6. Turn ON the motor.

331 (02/2000)

Releasing & Engaging a Drum Motor Equipped with a Manual Release Backstop (MRB) Device

To Release the Backstop Feature:

1. Bring the drum motor to full stop and disconnect power.
2. Remove the shaft cap located on the shaft end, opposite the junction box or cable entry.
3. Using a 10mm deep socket 1/4" drive and a ratchet; insert socket into the shaft and turn clockwise until the end, approximately 15 turns and allow motor to rotate freely in opposite direction.
4. Remove socket and re-install the shaft cap. The motor will operate in both directions.

To Engage the Backstop Feature - Repeat Steps 1 & 2:

3. Using a 10mm deep socket 1/4" drive and a ratchet; insert socket into the shaft and turn counter clockwise, approximately 15 turns.
NOTE: Do not exert force to turn the socket as some movement for the drum may be necessary to align the shaft to engage to its mating part. Forcing the rotation of the socket may result in damage to internal components.
4. Once re-engaged, remove the socket and re-install the shaft cap. The motor will operate in only the direction indicated by the brass arrow mounted on the side of the unit.

NOTE: The drum motor is shipped with the Backstop already engaged.

If you require assistance, please contact Van der Graaf Technical Support:
1 (866) 595-3292 or email: techsupport@vandergraaf.com

Oil Change Instructions

All Drum Motors are factory filled with oil that is free of detergent additives. It is recommended that oil changes be performed at 50,000 hour intervals.

NOTE: Do not use oil additives which can cause damage to the motor insulation or seals. Electrically conductive-bases oils, such as graphite and molybdenum disulfide, should not be used, as they will result in electric motor insulation damage.

OIL CHANGE

1. Allow the drum motor to cool to normal temperature.
2. Rotate the drum motor until the oil plug is located in the 6 o'clock position.
3. Unscrew the oil plug and allow the oil to drain completely.
Note: There may be internal pressure released when removing the oil plug, this is normal.
4. Refill the drum motor with the suggested oil type (see Oil Types below) and amount of oil (pages 10).



To verify the oil level, rotate the drum motor until the embossed arrow on the end flange (Models: TM160 - TM500), or the nameplate on the end flange (Model: TM127 mild steel only) is pointed in the 12 o'clock position. The oil plug will be approximately in the 4 o'clock position. The oil level should be up to the level of the oil plug.*

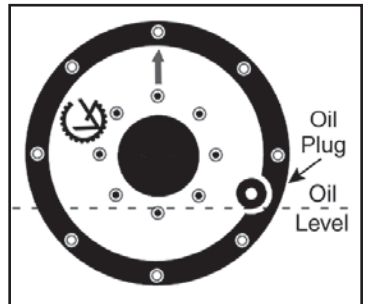

5. Re-install the oil plug and if available, install a new copper seal.

*For Airline Specified Drum Motors, please contact Van der Graaf Technical Support: 1 (866) 595-3292 or email: techsupport@vandergraaf.com for appropriate oil levels.

Oil Types

Oil Type	
Manufacturer	Oil Type
Petro Canada	Enduratex EP 150 Gear Oil
Castrol	Molub-Alloy Gear Oil 84
Chevron	NL Gear Compound 150
Esso / Imperial Oil	Spartan EP 150
Citgo	EP Compound 150
Gulf	EP Lubricant 140
Shell	Omala S2 G 150
Sunoco	SUNEP 150
Mobil	Mobil Gear 629, SHC 150

Food Grade Oil Type	
Manufacturer	Oil Type
Petro Canada	Purity FG EP 100
Mobil/Exxon	Nuto FG 100

Clutch Brake Oil Type	
Manufacturer	Oil Type
Petro Canada	Duratran Transmission/ Hydraulic Fluid

Drum Motor Oil Content (in Litres)

Face Width (inches)	Drum Motor Oil Content (in Litres) per Face Width								
	Type of Drum Motor								
	TM 100	TM 113	TM 127	TM 160	TM 215	TM 315	TM 400	TM 500A60	TM 500A75
9.84			0.30						
10.24	0.30	0.51							
10.83	0.31	0.54	0.35						
11.81			0.45						
12.20	0.35	0.61							
12.80			0.50						
13.78			0.55	1.30					
14.17	0.40	0.70							
15.75			0.70	1.60					
16.14	0.46	0.80							
16.73			0.75	1.70	2.50				
17.72			0.80	1.80	2.70				
18.11	0.52	0.90							
19.69			0.95	2.00	3.10	5.80			
20.08	0.57	1.00							
21.65			1.05	2.20	3.50	6.60			
22.05	0.63	1.10							
23.62			1.20	2.40	4.00	7.50	15.00	27.00	
24.02	0.68	1.19							
25.59			1.30	2.60	4.40	8.30	16.00	29.00	
25.98	0.74	1.29							
27.56			1.45	2.80	4.80	9.20	17.00	31.00	
27.95	0.80	1.39							
29.53			1.55	3.00	5.20	10.00	18.00	33.00	
29.92	0.84	1.49							
31.50			1.70	3.20	5.60	10.90	19.00	35.00	
31.89	0.91	1.59							
33.46			1.80	3.40	6.00	11.70	20.00	37.00	30.00
33.86	0.96	1.69							
35.43			1.95	3.60	6.40	12.60	21.00	39.00	31.50
35.83	1.02	1.79							
37.40			2.05	3.80	6.80	13.40	22.00	41.00	33.00
37.80	1.08	1.89							
39.38	1.12		2.20	4.00	7.20	14.30	23.00	43.00	34.50
39.76	1.13	1.98							
41.34			2.30	4.20	7.60	15.10	24.00	45.00	36.00
41.73	1.19	2.07							
43.31			2.45	4.40	8.00	16.00	25.00	47.00	37.50
Above 43.31" add	0.03 L per inch	0.05 L per inch	0.06 L per inch	0.10 L per inch	0.20 L per inch	0.40 L per inch	0.50 L per inch	1.00 L per inch	0.75 L per inch

Example: TM160 Drum Motor with face width of 33.46 inches requires 3.40 litres of oil.
 TM160 Drum Motor with face width of 44.31 inches requires 4.5 litres of oil.

(1 Litres = 0.265 gallons; 100 mm = 3.94 inches)

The unit will not run	<ol style="list-style-type: none">1. Check for correct connections.2. Check for correct power supply voltage.3. In a 3Ø unit check for equal voltage in all 3 phases.
The unit runs hot	<ol style="list-style-type: none">1. Make sure the unit is running with a belt. If the application does not require a belt be sure the motor is No Belt (NB) series.2. Load not to exceed the capacity of the unit.3. Check the current draw and make sure it is not higher than the rated current on the name plate.
The unit will hum, start but very slowly or not start at all.	<ol style="list-style-type: none">1. On 1Ø units, check the capacitor and starting switch.2. On 3Ø units, check for equal voltage on all 3 legs or open phase in the winding
The unit will trip off overload or fuses.	<ol style="list-style-type: none">1. Check the Drum Motor for a short to ground.2. If no short to ground is present, apply the rated input voltage and with an ammeter, measure the current and ensure that there is a balance of +/-10% variance between all three phases.
The unit is noisy	<ol style="list-style-type: none">1. Check the installation of the unit.2. Make sure that the arrow on the shaft, opposite to the junction box, is pointing up.3. Check for excess belt tension and relieve.

NOTE: If any of the above mentioned attempts to correct the problem have been performed and the problem persists contact Van der Graaf:

Technical Support: **1 (866) 595-3292**

Email: **techsupport@vandergraaf.com**

Spare Parts Online Order: **parts.vandergraaf.com**