

Connection Diagrams

SINGLE VOLTAGE - THREE PHASE

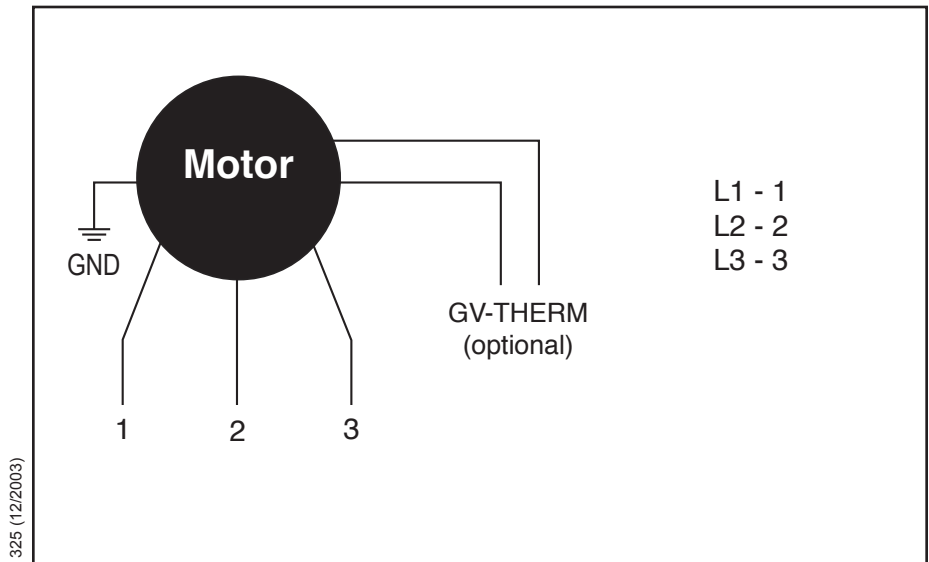

DUAL VOLTAGE - THREE PHASE (STAR/DELTA)

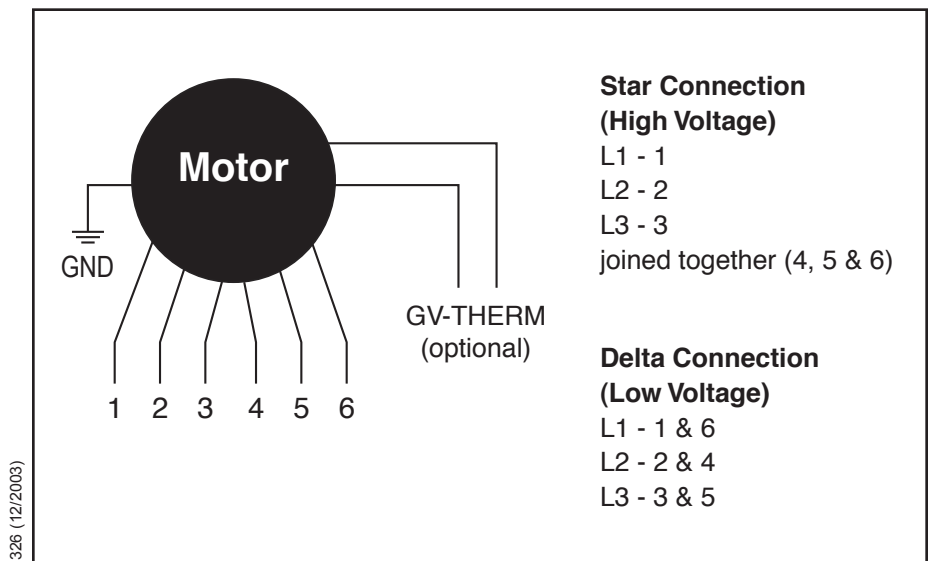

DUAL VOLTAGE - THREE PHASE (230/460 VOLTS)

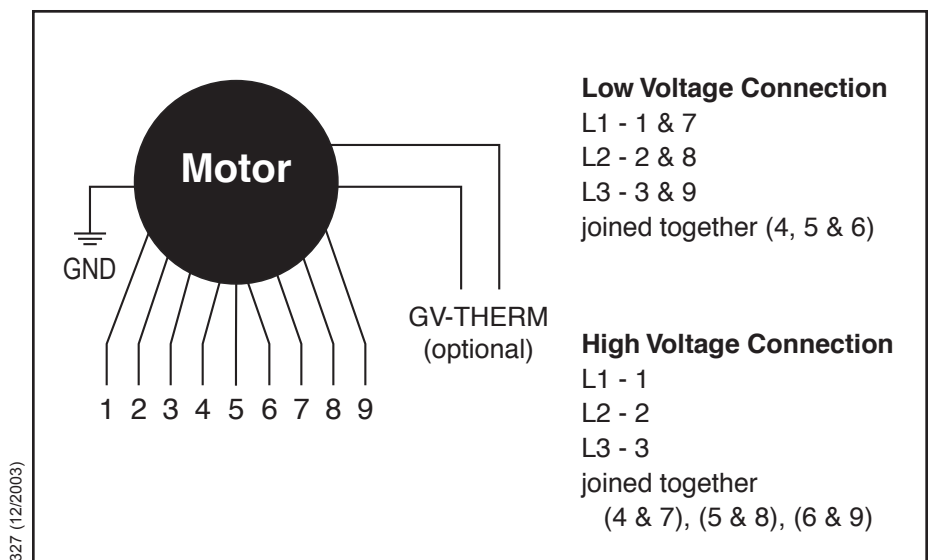

Connection Diagrams

SINGLE PHASE (110 VOLTS)

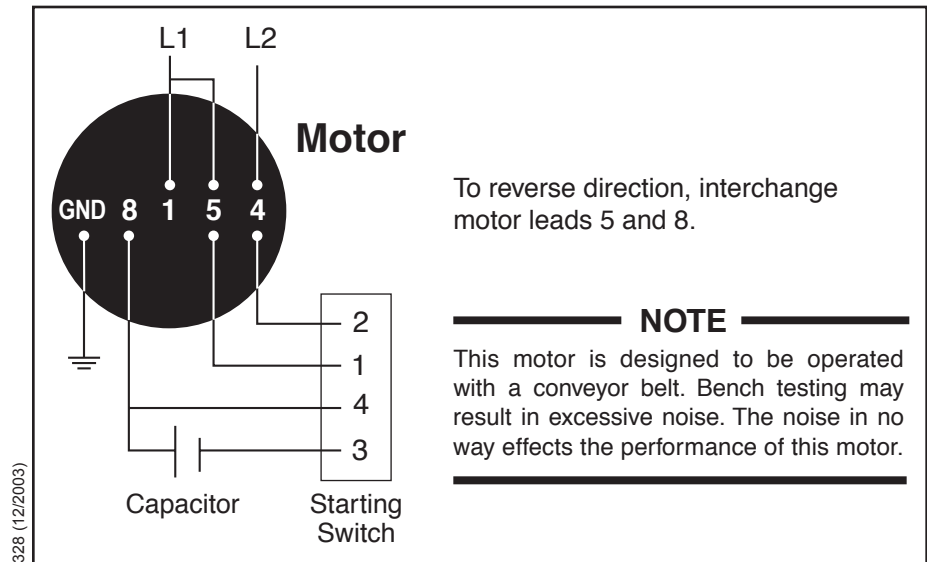

SINGLE PHASE (220 VOLTS)

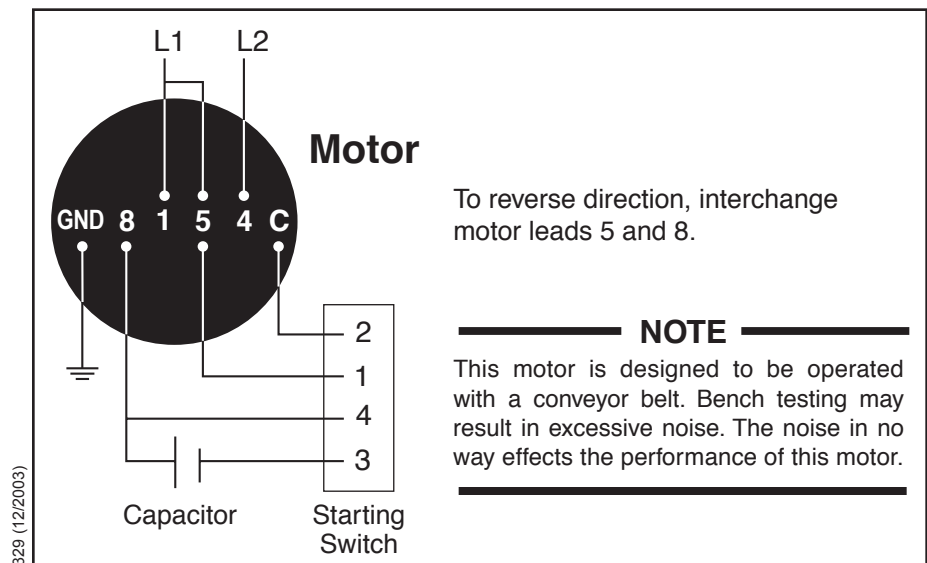

THREE PHASE WITH BRAKE (RTM)

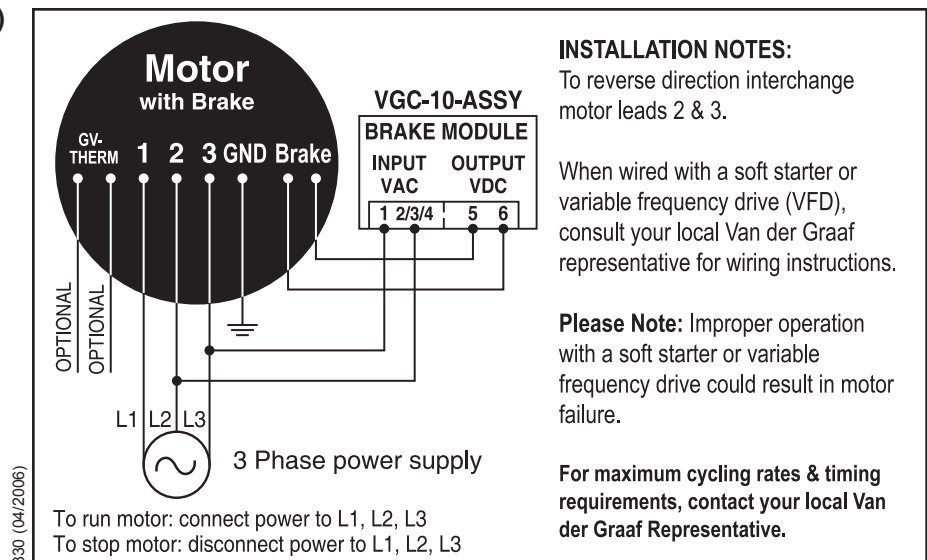

Connection Diagrams

THREE PHASE WITH CLUTCH BRAKE (CBTM)

