

# TM215 SERIES

# (8.5" diameter)

# CROSS SECTIONAL & PARTS DESCRIPTION

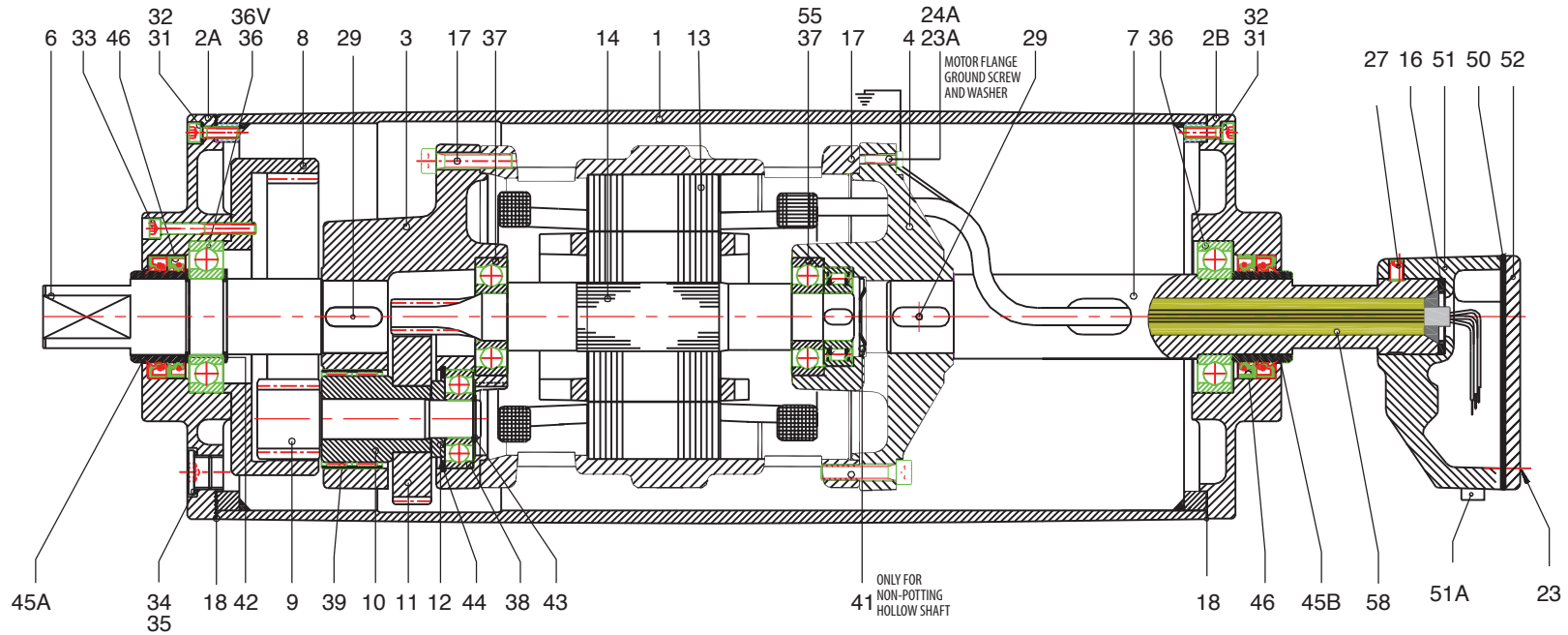

ITEM	PART DESCRIPTION	ITEM	PART DESCRIPTION	ITEM	PART DESCRIPTION	ITEM	PART DESCRIPTION
1	Shell	18	Gasket	38	Ball Bearing	58	Epoxy Resin
2A	End Flange	23	Fillister head Machine Screw	39	Needle Bearing		
2B	End Flange	23 A	M5X10 Slot Cheese HD Screw	41	Disc		
3	Gear Housing	24	Fillister head Machine Screw	42	Snap Ring		
4	Motor Flange	24 A	Washer	43	Snap Ring		
6	Shaft End	27	Set Screw	44	Snap Ring		
7	Hollow Shaft	29	Key	45 A	Bearing race		
8	External Gear	31	Socket Head Cap Screw	45 B	Bearing race		
9/10	Pinion With Bushing	32	Bonded Seal Washer	46	Oil Seal		
11	Gear	33	Socket Head Cap Screw	50	Nitrile Seal		
12	Distance Ring	34	Filler Plug	51	Junction Box		
13	Stator	35	Washer	51 A	Plug		
14	Rotor	36	Ball Bearing	52	Junction Box Cover		
16	Nitrile Gasket	36V	Cylindrical Bearing	55	Backstop Bearing (Optional)		
17	Internal Hex. Screw	37	Ball Bearing	57	Name Plate		