



SSV SERIES DRUM MOTORS | TM100 - TM215

ø4.0" to ø8.5" diameter • 0.11 to 7.5 hp

BELT PULL (BP) = (F0 + F1 + F2)

Roller Bed Conveyor

$F0 = 0.04 (2P + Q) L$

$F1 = 0.04 \times R \times L$

$F2 = R \times H$

Slider Bed Conveyor

$F0 = 1.1 \times P \times L \times C$

$F1 = 1.1 \times R \times L \times C$

$F2 = R \times H$

- Dimensions and Specifications
- Design Features and Benefits
- Belt Pull Calculations

RPM:

$= \frac{V}{\pi (d/12)}$

V = Velocity (ft/min)

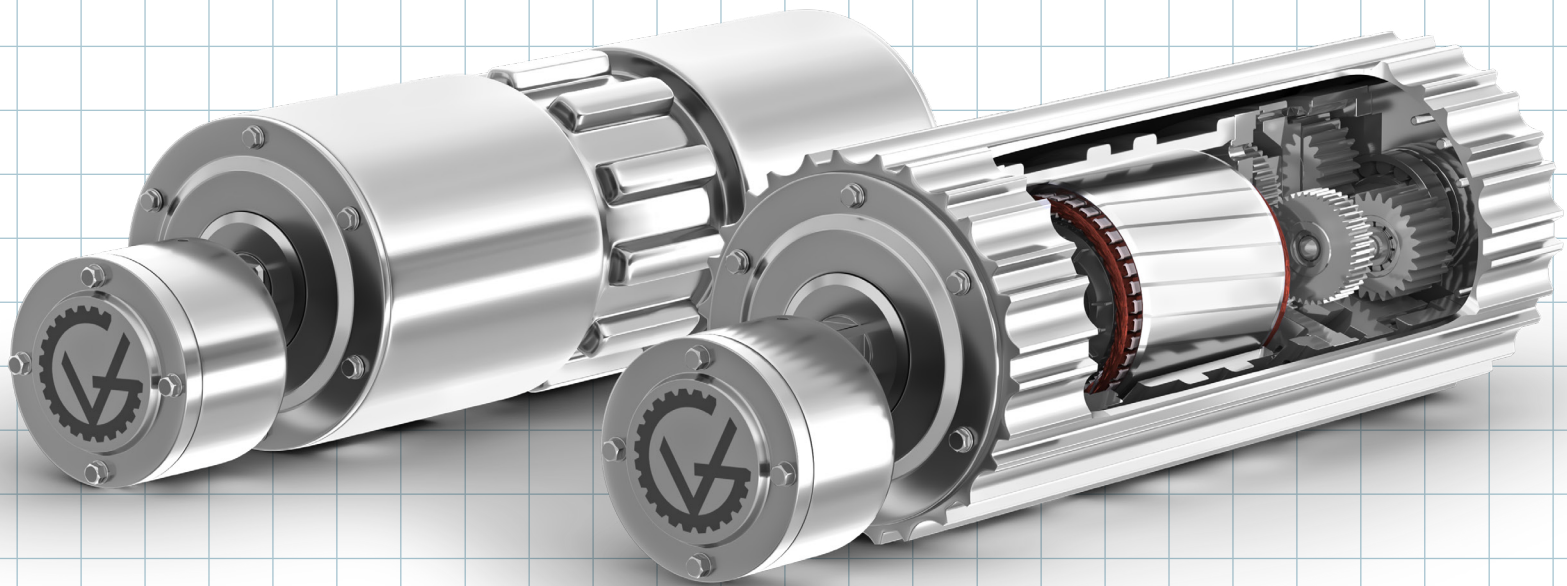

HORSEPOWER:

$HP = \frac{T''\text{lbs.} \times \text{RPM}}{63025}$

TORQUE:

$T''\text{lbs.} = \frac{63025 \times \text{HP}}{\text{RPM}}$



<i>The Drum Motor</i>			1-2
<i>Design Benefits</i>			1
<i>Standard Features & Options</i>			2
<i>Technical Information:</i>			3-18
<i>Drum Motor</i>	<i>Dimensions</i>	<i>Specifications</i>	
TM100B25 (4.0 \emptyset , 0.25 - 0.11 hp)	3	4-5	
TM113B25 (4.5" \emptyset , 0.75 - 0.16 hp)	6	7-8	
TM127B30 (5.0" \emptyset , 1.5 - 0.25 hp)	9	10	
TM138B30 (5.4" \emptyset , 1.5 - 0.25 hp)	11	12	
TM160B40 (6.5" \emptyset , 3.0 - 1.0 hp)	13	14	
TM215B40 (8.5" \emptyset , 7.5 - 2.0 hp)	15	16	
TM215B50 (8.5" \emptyset , 7.5 - 2.0 hp)	17	18	
<i>Belt Profile Chart (TM100 - TM215 Series)</i>			19-20
<i>Minimum Face Width Chart (TM100 - TM215 Series)</i>			21
<i>Belt Pull Calculations</i>			22

The SSV Series Drum Motor is constructed of 316-stainless steel and designed for hygienic belt conveyor applications where food safety is paramount. The drum motor is a one-component belt drive with all components enclosed inside the drive roller, protected from outside elements. With no external components such as motor, gearbox, and bearings, the drum motor improves hygiene and workforce safety and eliminates routine maintenance cycles, reducing downtime and expenses associated with traditional conveyor belt drives.

For modular, wire mesh, and monolithic thermoplastic conveyor belts, the SSV Drum Motor drives the belt without the use of sprockets. The belt profile is machined directly onto the drive drum or directly onto an exchangeable drive sleeve. SSV Series Drum Motors eliminate gaps and crevices, reducing water and time used for washdown by 50%.

All components of the drum motor are designed for 80,000 hours of continuous operation with no required maintenance. The 96% mechanically efficient gear reducer is in-line with the electric motor, increasing energy efficiency by 25% to 30%, resulting in lower energy consumption and costs. The SSV Series Drum Motor is a hygienic, space-saving, less complex, efficient, reliable, and maintenance-free solution to power belt conveyors. Available in a wide range of diameters, belt speeds, horsepower, face widths, and options to suit all types of belt conveyor applications.

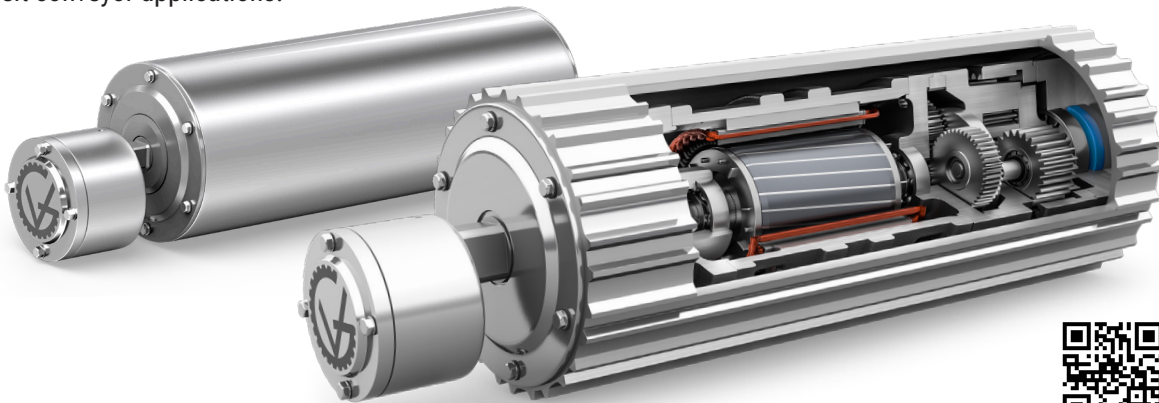

[View Video](#)

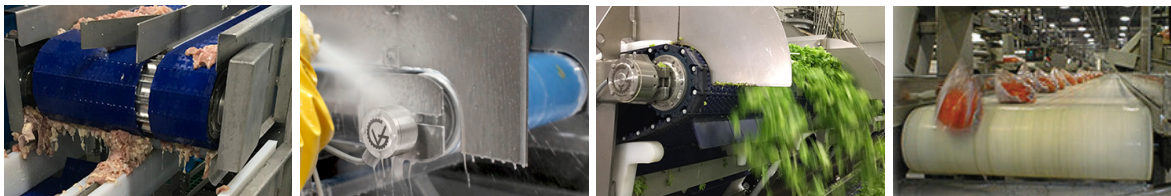

INCREASE HYGIENE

All enclosed 316-stainless steel SSV Drum Motors feature an IP69K-rated sealing system, withstand pressure washdown up to 3,000 psi, and drive modular conveyor belts without the use of sprockets.

REDUCE ENERGY CONSUMPTION

With 96% mechanical efficiency and a premium-efficiency electric motor, SSV Drum Motors reduces energy consumption, resulting in energy savings of 25% to 30% over traditional external conveyor drives.

ELIMINATE MAINTENANCE CYCLES

Maintenance-free SSV Drum Motors are designed for 80,000 hours of continuous operation before an oil change that is performed without removing the drive. With no external drive components, the drum motor eliminates the constant need for lubricating bearings, chain adjustment, and routine maintenance cycles.

INCREASE WORKFORCE SAFETY

With all components enclosed inside the drive roller, the SSV Drum Motor eliminates the external components of a traditional conveyor drive that could pose hazards to workforce safety.

ENHANCE SPACE UTILIZATION

Low-profile SSV Drum Motors reduce the overall footprint of the conveyor (area the conveyor occupies), allowing more conveyors to fit on the same floor or overhead space.

STANDARD FEATURES:

PREMIUM-EFFICIENCY ELECTRIC MOTORS

All electric motors are manufactured in-house by VDG to Class H insulation standards, are inverter-duty, and can be supplied for all standard and non-standard voltage at 50 Hz or 60 Hz for 3 phase applications. All VDG electric motors undergo a **Vacuum Pressure Impregnation (VPI)** process, increasing the life of the electric motor.

PRESSURE EQUALIZATION SYSTEM (PES)

Depending on the application, the heat generated by the electric motor and gear reducer during normal operation will raise the internal pressure up to 18 psi. The internal pressure will cause tighter than normal engagement of the oil seals to the shaft, resulting in premature oil seal failure. The increased internal pressure will result in oil leakage and a higher operating temperature. The pressure equalization system (PES) releases the internal pressure above 0.5 psi. Lower internal pressure eliminates oil leaks, reduces the operating temperature, and increases the electric motor and gear reducer performance.

IP69K SEALING SYSTEM

Withstands pressure washdown up to 3,000 psi

OPTIONS:

NON-STANDARD LENGTH / EXTRA LONG FACE WIDTH - Contact your VDG technical representative for details.

MECHANICAL BACKSTOP (TB)

To prevent rollback for incline conveyors, the backstop device in the drum motor allows the drum motor to rotate only in one direction.

ELECTROMAGNETIC BRAKE (RTM)

The mechanical electromagnetic brake inside the drum motor allows the drum motor to start and stop 45 times per minute. Available for TM127 and higher.

OVERLOAD PROTECTION (GV-THERM)

The GV-THERM, a thermal bimetal device embedded into the motor windings that reacts to temperature, provides an additional layer of thermal overload protection.

LAGGING

VDG offers a complete line of USDA approved white or blue nitrile rubber lagging.

BELT PROFILES

Belt profiles are available either machined directly onto the drive drum (SSV Drum Motor) or machined onto an exchangeable drive sleeve (SSV-XP Drum Motor).

SSV Series Drum Motors drive modular, wire mesh, and monolithic conveyor belts without the use of sprockets.

SSV Drum Motor with Continuous Profiled Drum

Profile is machined directly onto the drive drum.

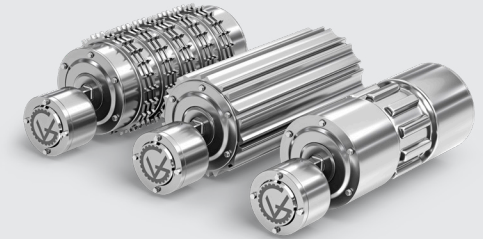

SSV-XP Drum Motor with Exchangeable Profiled Sleeve

Belt profile is machined directly onto an exchangeable drive sleeve (XP) which is easily removed & exchanged for another profiled sleeve to match the belt required on the conveyor without changing the drum motor. The VDG patented profiled sleeve is available for TM127 and TM160 only.

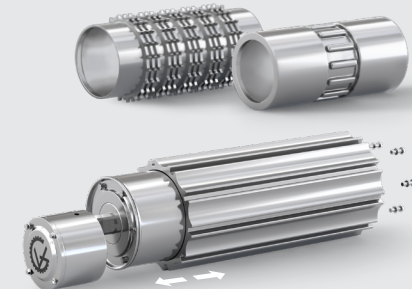

[View Demo](#)

Profiles are available for various belt manufacturers.

TM100B25 Drum Motor (matching Idler KT100B25**)

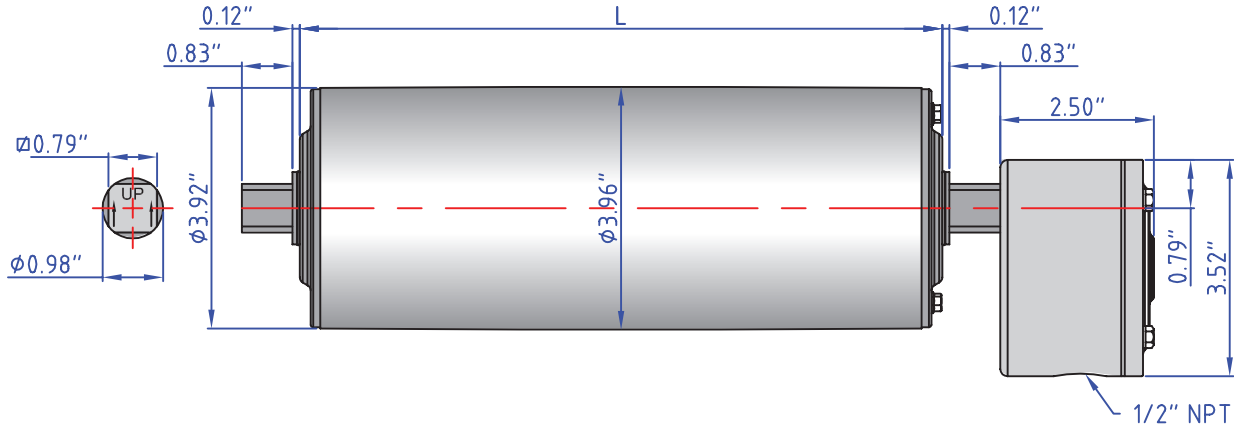

Standard drum motor face widths* (L) in inches:

10.24	10.83	12.20	14.17	16.14	18.11	20.08	22.05	24.02	25.98
27.95	29.92	31.89	33.86	35.83	37.80	39.76	41.73	43.70	45.67

*Some face widths are not available in all horsepower. For minimum available face widths refer to page 21.

**Idler dimensions are identical to the drum motor with no junction box.

Brackets: 100-AB20

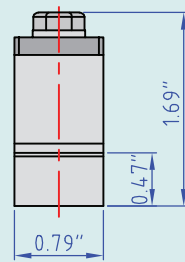
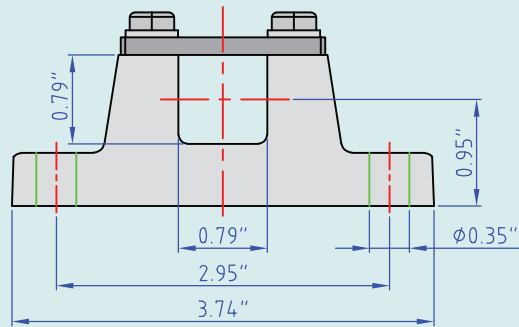

Cable Option:

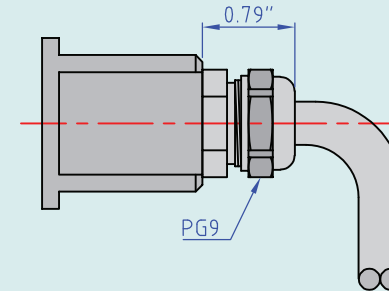

TM100B25 Drum Motor

0.25 HP

V (ft/min) M/G	409 4/S2	327 4/S2	291 4/S2	258 4/S2	227 4/S2	199 4/S2	177 4/PL2	157 4/PL2	149 4/PL2	132 4/PL2	111 4/PL2	106 4/PL2	93 4/PL2	83 4/PL2	69 4/PL2
Belt Pull (lbf)	20	25	28	32	36	41	47	52	55	63	74	78	88	100	119
Drum RPM	397	317	282	250	220	193	172	152	145	128	108	103	90	81	67

V (ft/min) M/G	56 4/PL2	44 4/PL3	37 4/PL3	33 4/PL3	27 4/PL3	23 4/PL3	20 4/PL3	17 4/PL3	14 4/PL3
Belt Pull (lbf)	148	189	225	253	274	274	274	274	274
Drum RPM	54	43	36	32	26	22	19	17	14

0.16 HP

V (ft/min) M/G	258 4/S2	227 4/S2	199 4/S2	177 4/PL2	157 4/PL2	149 4/PL2	132 4/PL2	111 4/PL2	106 4/PL2	93 4/PL2	83 4/PL2	69 4/PL2	56 4/PL2	44 4/PL3	37 4/PL3
Belt Pull (lbf)	20	23	27	30	34	35	40	48	50	57	64	76	94	121	144
Drum RPM	250	220	193	172	152	145	128	108	103	90	81	67	54	43	36

V (ft/min) M/G	33 4/PL3	27 4/PL3	23 4/PL3	20 4/PL3	17 4/PL3	14 4/PL3
Belt Pull (lbf)	162	193	230	259	274	274
Drum RPM	32	26	22	19	17	14

0.16 HP

V (ft/min) M/G	305 6/S2	273 6/S2	218 6/S2	194 6/S2	172 6/S2	152 6/S2	105 6/PL2	99 6/PL2	88 6/PL2	74 6/PL2	71 6/PL2	62 6/PL2	55 6/PL2	46 6/PL2	37 6/PL2
Belt Pull (lbf)	17	19	24	27	31	35	50	53	60	71	74	85	96	114	142
Drum RPM	296	265	212	188	167	148	102	96	85	72	69	60	53	45	36

V (ft/min) M/G	29 6/PL3	24 6/PL3	22 6/PL3	18 6/PL3	15 6/PL3	13 6/PL3	11 6/PL3	9 6/PL3
Belt Pull (lbf)	181	216	243	274	274	274	274	274
Drum RPM	28	23	21	17	15	13	11	9

0.14 HP

V (ft/min) M/G	258 4/S2	227 4/S2	199 4/S2	177 4/PL2	157 4/PL2	149 4/PL2	133 4/PL2	111 4/PL2	106 4/PL2	93 4/PL2	83 4/PL2	69 4/PL2	56 4/PL2	44 4/PL3	37 4/PL3
Belt Pull (lbf)	18	20	23	26	29	31	35	42	42	50	56	67	83	106	126
Drum RPM	250	220	193	172	152	145	128	108	103	90	81	67	54	43	36

V (ft/min) M/G	33 4/PL3	27 4/PL3	23 4/PL3	20 4/PL3	17 4/PL3	14 4/PL3
Belt Pull (lbf)	142	169	201	227	271	274
Drum RPM	32	26	22	19	17	14

V = Belt Speed (ft/min)

M/G = Motor/Gear Reducer Configuration (at rated horsepower)

High Speed
Low Torque

 2/S2 4/S2 6/S2 2/S3 4/S3 6/S3 2/PL2 4/PL2 6/PL2 2/PL3 4/PL3 6/PL3
Low Speed
High Torque

TM100B25 Drum Motor

0.11 HP

V (ft/min) M/G	194 6/S2	172 6/S2	151 6/S2	118 6/PL2	105 6/PL2	99 6/PL2	88 6/PL2	74 6/PL2	71 6/PL2	62 6/PL2	55 6/PL2	46 6/PL2	37 6/PL2	29 6/PL3	24 6/PL3
Belt Pull (lbf)	19	21	24	31	35	36	41	49	51	58	66	79	97	125	148
Drum RPM	188	167	147	115	102	96	85	72	69	60	53	45	36	28	23

V (ft/min) M/G	22 6/PL3	18 6/PL3	15 6/PL3	13 6/PL3	11 6/PL3	9 6/PL3
Belt Pull (lbf)	167	200	237	267	274	274
Drum RPM	21	17	15	13	11	9

V = Belt Speed (ft/min)

M/G = Motor/Gear Reducer Configuration (at rated horsepower)

High Speed
Low Torque



Low Speed
High Torque

TM113B25 Drum Motor (matching Idler KT113B25**)

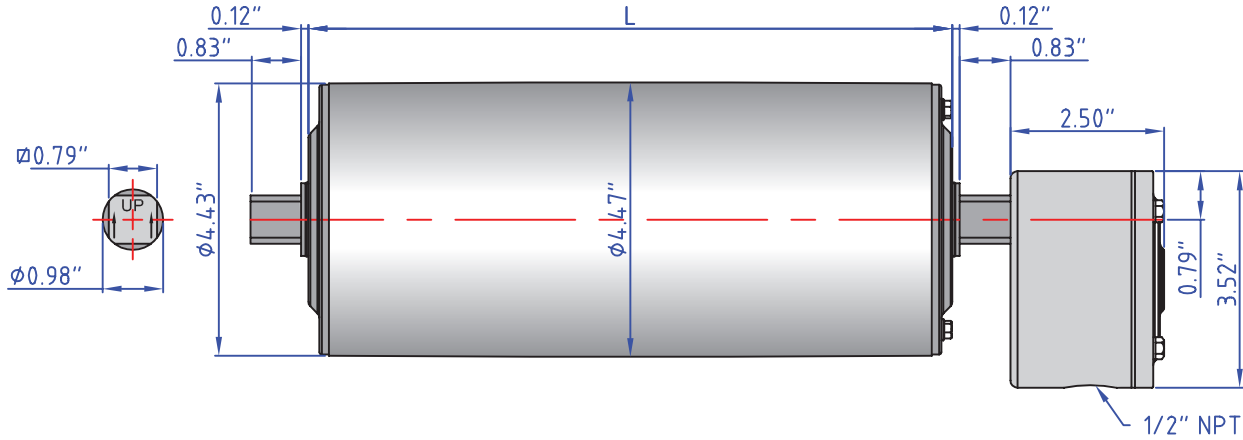

Standard drum motor face widths* (L) in inches:

10.24	10.83	12.20	14.17	16.14	18.11	20.08	22.05	24.02	25.98
27.95	29.92	31.89	33.86	35.83	37.80	39.76	41.73	43.70	45.67

*Some face widths are not available in all horsepower. For minimum available face widths refer to page 21.

**Idler dimensions are identical to the drum motor with no junction box.

Brackets: 100-AB20

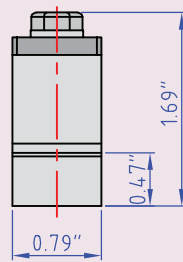
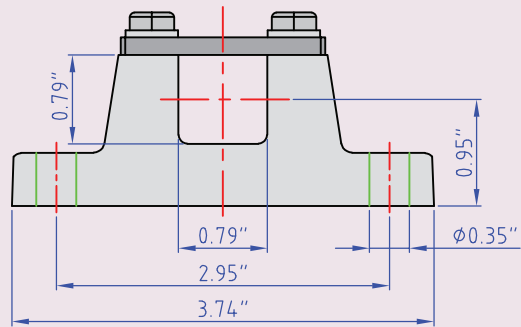

Cable Option:

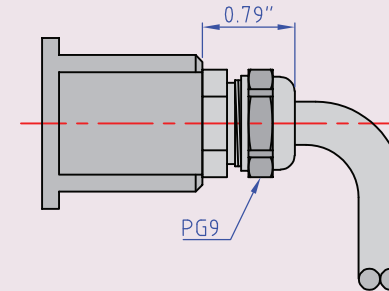

TM113B25 Drum Motor

0.75 HP

V (ft/min) M/G	1039 2/S2	945 2/S2	756 2/S2	661 2/S2	591 2/S2	520 2/S2	449 2/S2
Belt Pull (lbf)	22	24	31	35	39	45	50
Drum RPM	892	811	649	568	507	446	385

0.5 HP

V (ft/min) M/G	1039 2/PL2	945 2/S2	756 2/S2	661 2/S2	591 2/S2
Belt Pull (lbf)	15	17	21	23	26
Drum RPM	892	881	649	568	507

0.5 HP

V (ft/min) M/G	520 4/S2	472 4/S2	378 4/S2	331 4/S2	295 4/S2	260 4/S2	224 4/S2	201 4/PL2	177 4/S2	165 4/PL2	154 4/PL2	142 4/S2	130 4/PL2	118 4/PL2	106 4/PL2
Belt Pull (lbf)	30	33	41	47	52	60	69	75	88	91	98	109	116	127	141
Drum RPM	446	406	325	284	254	223	193	172	152	142	132	122	112	101	91

V (ft/min) M/G	94 4/PL2	80 4/PL2	64 4/PL2
Belt Pull (lbf)	161	187	215
Drum RPM	81	69	55

0.34 HP

V (ft/min) M/G	1039 2/S2	945 2/S2	756 2/S2	661 2/S2	591 2/S2
Belt Pull (lbf)	10	11	14	16	18
Drum RPM	892	811	649	568	507

0.34 HP

V (ft/min) M/G	520 4/S2	472 4/S2	378 4/S2	331 4/S2	295 4/S2	260 4/S2	224 4/S2	201 4/PL2	177 4/PL2	165 4/PL2	154 4/PL2	130 4/PL2	118 4/PL2	106 4/PL2	94 4/PL2
Belt Pull (lbf)	21	22	28	32	36	40	47	50	57	62	66	79	86	95	108
Drum RPM	446	406	325	284	254	223	193	172	152	142	132	112	101	91	81

V (ft/min) M/G	80 4/PL2	64 4/PL2
Belt Pull (lbf)	126	159
Drum RPM	69	55

V = Belt Speed (ft/min)

M/G = Motor/Gear Reducer Configuration (at rated horsepower)

High Speed
Low Torque

 2/S2 4/S2 6/S2 2/S3 4/S3 6/S3 2/PL2 4/PL2 6/PL2 2/PL3 4/PL3 6/PL3
Low Speed
High Torque

TM113B25 Drum Motor

0.34 HP

V (ft/min) M/G	236 6/S2	213 6/S2	189 6/S2	165 6/S2	142 6/S2	118 6/S2	94 6/S2	69 6/PL2	59 6/PL2	50 6/PL2	40 6/PL2
Belt Pull (lbf)	45	50	55	64	74	89	111	149	172	205	215
Drum RPM	203	183	162	142	122	101	81	59	51	43	34

0.25 HP

V (ft/min) M/G	378 4/S2	331 4/S2	295 4/S2	260 4/S2	224 4/S2	201 4/PL2	177 4/PL2	165 4/PL2	154 4/PL2	130 4/PL2	118 4/PL2	106 4/PL2	94 4/PL2	80 4/PL2	64 4/PL2
Belt Pull (lbf)	20	22	25	29	34	36	41	44	48	56	62	69	78	91	115
Drum RPM	325	284	254	223	193	172	152	142	132	112	101	91	81	69	55

V (ft/min) M/G	47 4/PL3	43 4/PL3	38 4/PL3	31 4/PL3	26 4/PL3
Belt Pull (lbf)	148	165	185	215	215
Drum RPM	41	37	32	26	22

0.25 HP

V (ft/min) M/G	213 6/S2	189 6/S2	165 6/S2	142 6/S2	59 6/PL2	50 6/PL2	40 6/PL2
Belt Pull (lbf)	36	40	46	53	123	148	182
Drum RPM	183	162	142	122	51	43	34

0.16 HP

V (ft/min) M/G	260 4/S2	224 4/S2	201 4/PL2	177 4/PL2	165 4/PL2	154 4/PL2	130 4/PL2	118 4/PL2	106 4/PL2	94 4/PL2	80 4/PL2	64 4/PL2	43 4/PL3	26 4/PL3	17 4/PL3
Belt Pull (lbf)	20	22	24	27	30	32	37	41	46	51	61	77	109	180	215
Drum RPM	223	193	172	152	142	132	112	101	91	81	69	55	37	22	14

V = Belt Speed (ft/min)

M/G = Motor/Gear Reducer Configuration (at rated horsepower)

High Speed
Low Torque

Low Speed
High Torque

TM127B30 Drum Motor (matching Idler KT127B30**)

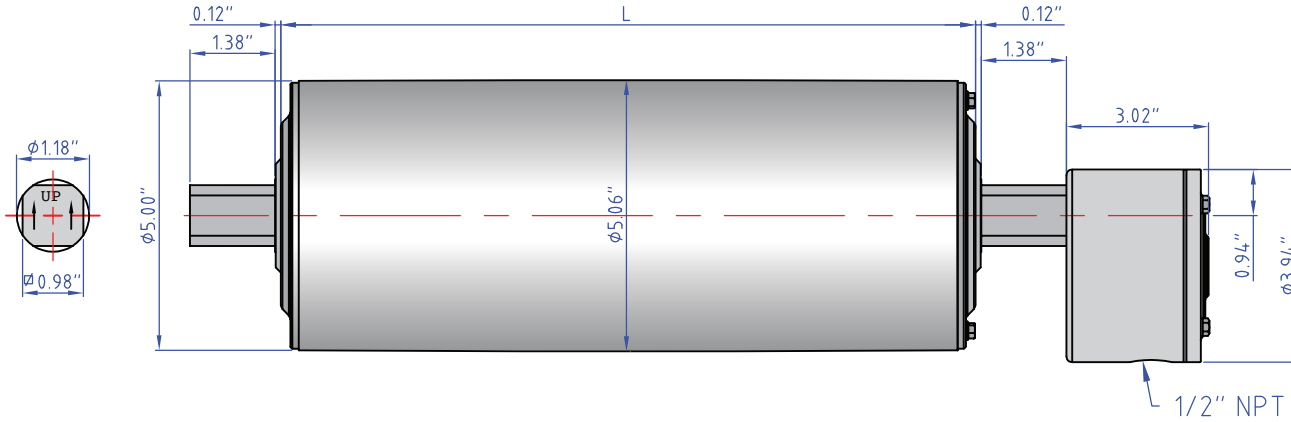

Standard drum motor face widths* (L) in inches:

10.83	11.81	13.78	15.75	17.72	19.69	21.65	23.62	25.59	27.56
29.53	31.50	33.46	35.43	37.40	39.37	41.34	43.31	45.28	47.24

*Some face widths are not available in all horsepower. For minimum available face widths refer to page 21.

**Idler dimensions are identical to the drum motor with no junction box.

Brackets: 160-AB30

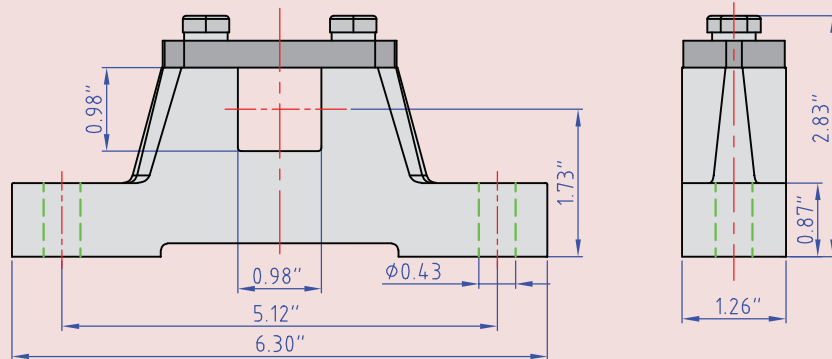

PES Cable Option:

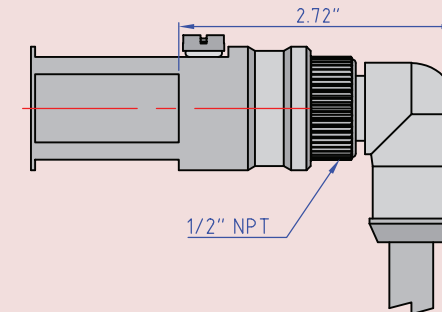

TM127B30 Drum Motor

1.5 HP

V (ft/min) M/G	316 4/S2	237 4/S2	201 4/S2	124 4/S2
Belt Pull (lbf)	156	207	244	396
Drum RPM	243	182	155	95

1.0 HP

V (ft/min) M/G	646 2/S2	484 2/S2	411 2/S2	316 4/S2	237 4/S2	201 4/S2	147 4/S2	124 4/S2	110 4/S2	73 4/PL2	58 4/PL2	49 4/PL2	38 4/PL2
Belt Pull (lbf)	51	68	80	104	138	163	223	264	298	449	565	669	767
Drum RPM	497	372	316	243	182	155	113	95	85	56	45	38	29

0.75 HP

V (ft/min) M/G	651 2/S2	488 2/S2	414 2/S2	328 4/S2	246 4/S2	209 4/S2	152 4/S2	134 4/S3	114 4/S2	97 4/S2	87 6/S2	74 6/S2	62 4/S3	56 4/S3	50 4/PL2
Belt Pull (lbf)	38	50	59	75	100	118	162	183	216	253	282	332	366	408	491
Drum RPM	501	375	318	252	189	161	117	103	88	75	67	57	48	43	38

V (ft/min) M/G 40 4/PL2

Belt Pull (lbf) 617

Drum RPM 31

0.5 HP

V (ft/min) M/G	321 4/S2	241 4/S2	205 4/S2	149 4/S2	131 4/S2	98 4/S2	83 4/S2	64 6/S2	54 4/S3	41 4/S3	33 6/PL2	26 6/PL2
Belt Pull (lbf)	51	68	80	110	125	167	197	256	303	400	496	630
Drum RPM	247	185	158	115	101	75	64	49	42	32	25	20

0.34 HP

V (ft/min) M/G	322 4/S2	241 4/S2	205 4/S2	149 4/S2	131 4/S2	99 4/S2	84 4/S2	61 4/S3	54 4/S3	41 4/S3
Belt Pull (lbf)	35	46	54	75	85	113	133	183	206	272
Drum RPM	248	185	158	115	101	76	65	47	42	32

0.25 HP

V (ft/min) M/G	11.1 4/PL3	8.7 4/PL3	7.3 4/PL3	5.8 4/PL3
Belt Pull (lbf)	738	767	767	767
Drum RPM	8.5	6.7	5.6	4.5

V = Belt Speed (ft/min)

M/G = Motor/Gear Reducer Configuration (at rated horsepower)

High Speed
Low Torque

Low Speed
High Torque

TM138B30 Drum Motor (matching Idler KT138B30**)

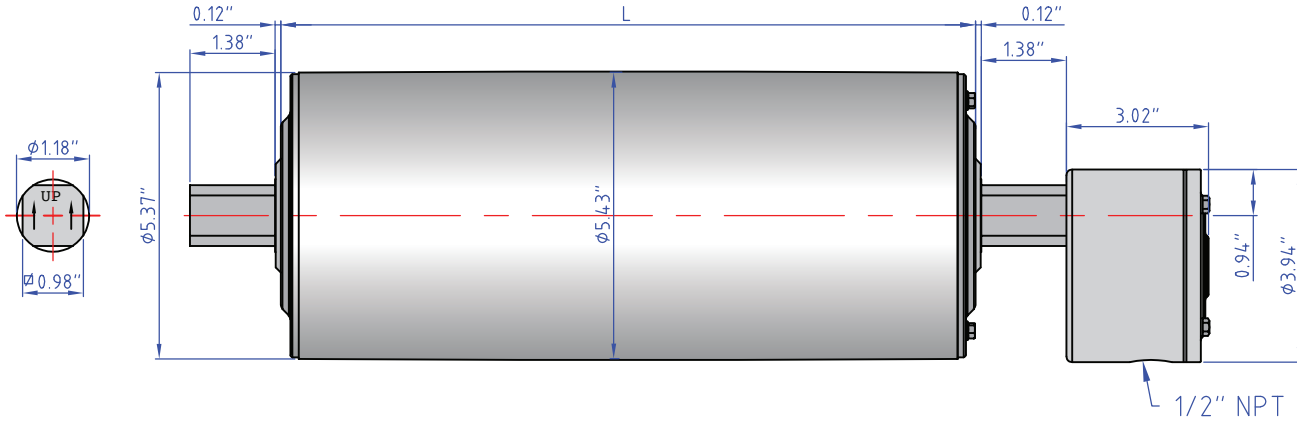

Standard drum motor face widths* (L) in inches:

10.83	11.81	13.78	15.75	17.72	19.69	21.65	23.62	25.59	27.56
29.53	31.50	33.46	35.43	37.40	39.37	41.34	43.31	45.28	47.24

*Some face widths are not available in all horsepower. For minimum available face widths refer to page 21.

**Idler dimensions are identical to the drum motor with no junction box.

Brackets: 160-AB30

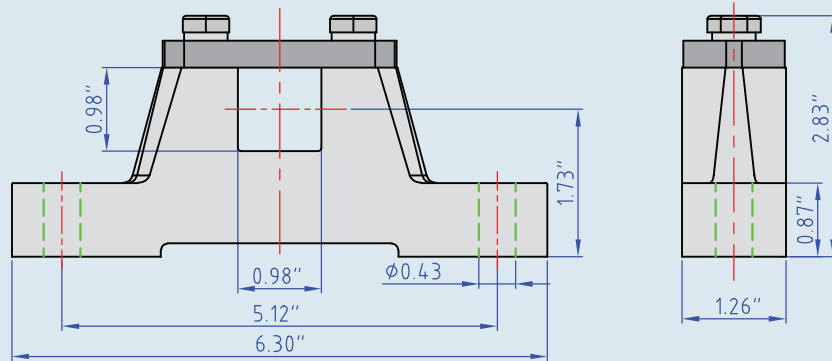

PES Cable Option:

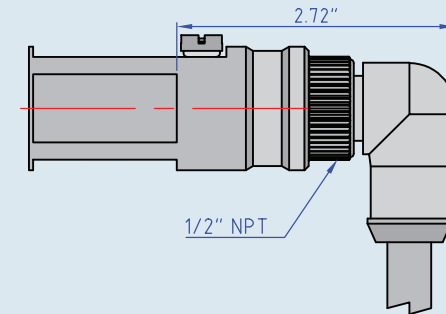

TM138B30 Drum Motor

1.5 HP

V (ft/min) M/G	343 4/S2	258 4/S2	218 4/S2	135 4/S2
Belt Pull (lbf)	156	208	246	398
Drum RPM	242	181	154	95

1.0 HP

V (ft/min) M/G	702 2/S2	526 2/S2	447 2/S2	343 4/S2	258 4/S2	218 4/S2	160 4/S2	135 4/S2	120 4/S2	79 4/PL2	63 4/PL2	53 4/PL2	41 4/PL2
Belt Pull (lbf)	51	68	80	104	139	164	224	266	299	451	568	672	767
Drum RPM	494	370	315	242	181	154	112	95	84	56	44	37	29

0.75 HP

V (ft/min) M/G	707 2/S2	530 2/S2	450 2/S2	356 4/S2	267 4/S2	227 4/S2	165 4/S2	146 4/S3	124 4/S2	105 4/S2	95 6/S2	80 6/S2	67 4/S3	61 4/S3	54 4/PL2
Belt Pull (lbf)	38	50	59	75	100	118	162	183	216	253	282	332	366	408	491
Drum RPM	501	375	318	252	189	161	117	103	88	75	67	57	48	43	38

V (ft/min) M/G 43 4/PL2

Belt Pull (lbf) 617

Drum RPM 31

0.5 HP

V (ft/min) M/G	349 4/S2	262 4/S2	223 4/S2	162 4/S2	142 4/S2	106 4/S2	90 4/S2	70 6/S2	59 4/S3	45 4/S3	36 6/PL2	28 6/PL2
Belt Pull (lbf)	51	68	80	111	126	168	198	257	305	402	499	633
Drum RPM	246	184	157	114	100	75	64	49	41	31	25	20

0.34 HP

V (ft/min) M/G	350 4/S2	262 4/S2	223 4/S2	162 4/S2	142 4/S2	108 4/S2	91 4/S2	66 4/S3	59 4/S3	45 4/S3
Belt Pull (lbf)	35	46	55	75	85	113	133	184	207	273
Drum RPM	246	184	157	114	100	76	64	47	41	31

0.25 HP

V (ft/min) M/G	12 4/PL3	9 4/PL3	8 4/PL3	6 4/PL3
Belt Pull (lbf)	742	767	767	767
Drum RPM	8	7	6	4

V = Belt Speed (ft/min)

M/G = Motor/Gear Reducer Configuration (at rated horsepower)

High Speed
Low Torque

 2/S2 4/S2 6/S2 2/S3 4/S3 6/S3 2/PL2 4/PL2 6/PL2 2/PL3 4/PL3 6/PL3
Low Speed
High Torque

TM160B40 Drum Motor (matching Idler KT160B40**)

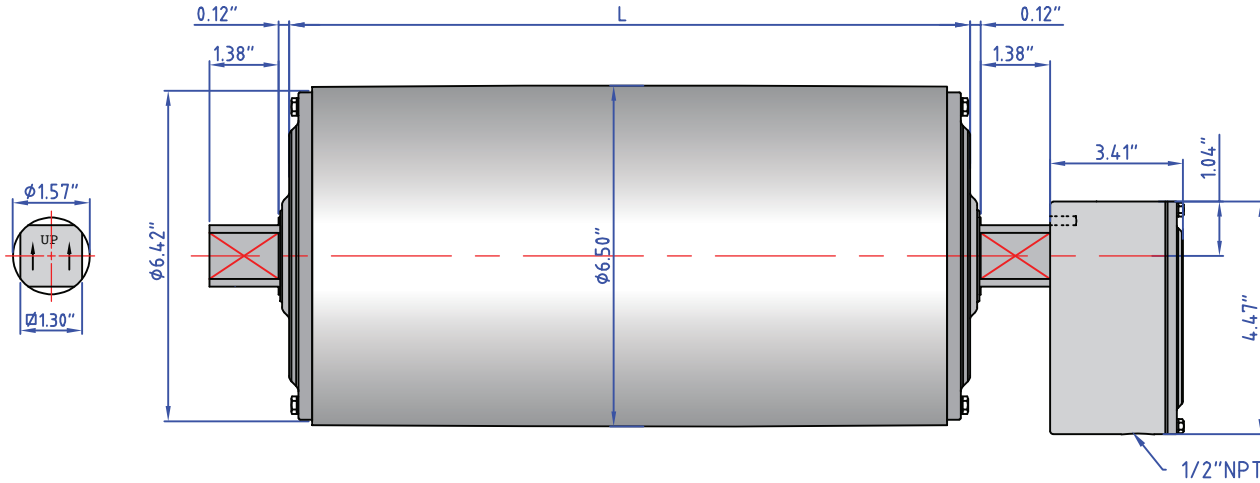

NOTE: Junction Box **does not rotate**.
Power entry at 6 o'clock position.

Standard drum motor face widths* (L) in inches:

15.75	16.73	17.72	19.69	21.65	23.62	25.59	27.56	29.53
31.50	33.46	35.43	37.40	39.37	41.34	43.31	45.28	47.24

*Some face widths are not available in all horsepower. For minimum available face widths refer to page 21.

**Idler dimensions are identical to the drum motor with no junction box.

Brackets: 160-AB40

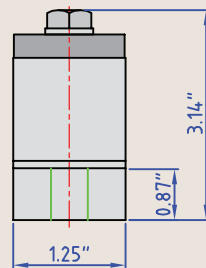
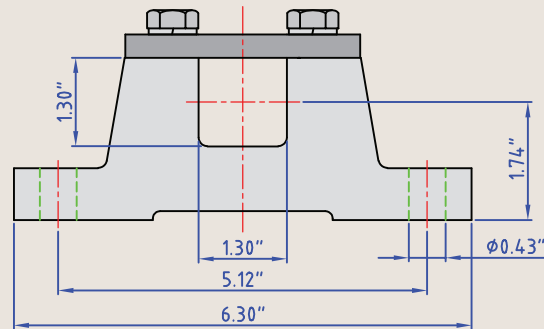

PES Cable Option:

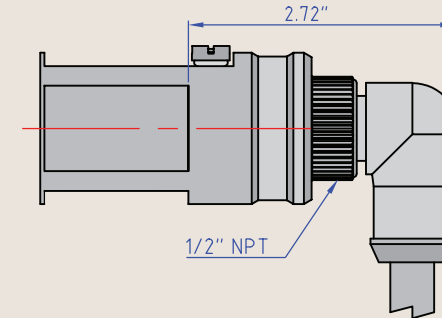

TM160B40 Drum Motor

3.0 HP

V (ft/min) M/G	272 2/S2	236 2/S2	213 2/S2	201 2/S2	189 2/S2
Belt Pull (lbf)	339	391	434	460	488
Drum RPM	160	139	126	119	111

2.0 HP

V (ft/min) M/G	272 2/S2	236 2/S2	213 2/S2	201 2/S2	189 2/S2	165 4/S2	154 4/S2	142 4/S2	130 4/S2	114 2/S3	108 2/PL2	87 2/PL2	74 4/PL2
Belt Pull (lbf)	232	266	296	313	333	381	410	444	484	407	580	650	800
Drum RPM	160	139	125	118	111	97	90	83	76	67	64	50	44

1.5 HP

V (ft/min) M/G	165 4/S2	154 4/S2	142 4/S2	130 4/S2	118 2/S2	106 4/S2	94 4/S2
Belt Pull (lbf)	280	290	333	355	391	434	489
Drum RPM	97	90	83	76	69	63	56

1.0 HP

V (ft/min) M/G	130 4/S2	118 4/S2	106 4/S2	94 4/S2	80 4/S2	73 4/S2	57 4/S3	54 4/PL2	47 4/S3	43 4/PL2
Belt Pull (lbf)	242	266	296	333	392	315	547	561	489	525
Drum RPM	76	69	63	56	47	43	33	32	28	25

Note: Highlighted are available with an Electromagnetic Brake unit (RTM160B40)

V = Belt Speed (ft/min)

M/G = Motor/Gear Reducer Configuration (at rated horsepower)

High Speed
Low Torque



Low Speed
High Torque

TM215B40 Drum Motor (matching Idler KT215B40**)

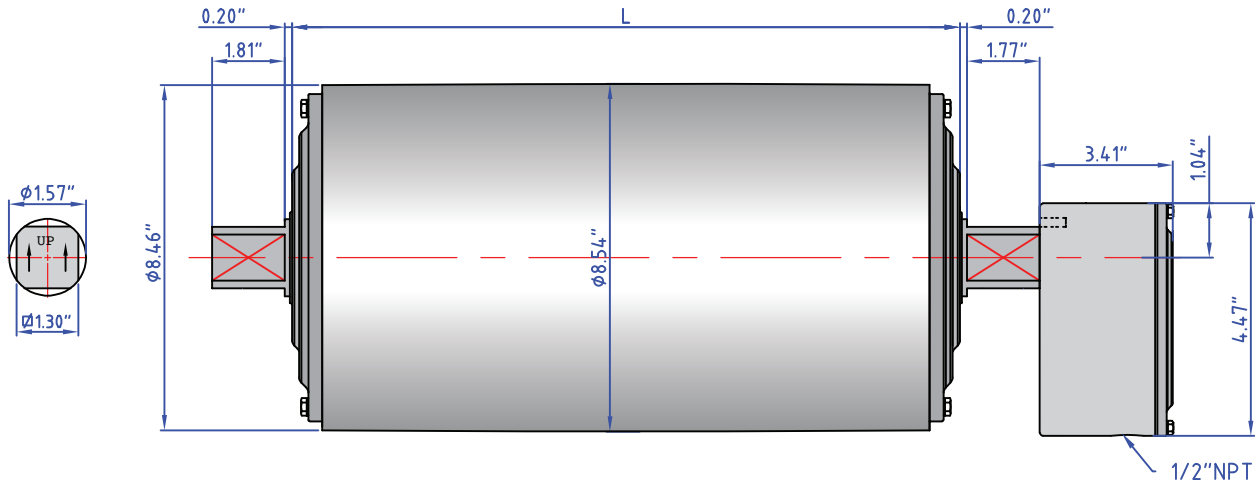

NOTE: Junction Box **does not rotate**.
Power entry at 6 o'clock position.

Standard drum motor face widths* (L) in inches:

19.69	21.65	23.62	25.59	27.56	29.53	31.50	33.46	35.43
37.40	39.37	41.34	43.31	45.28	47.24			

*Some face widths are not available in all horsepower. For minimum available face widths refer to page 21.

**Idler dimensions are identical to the drum motor with no junction box.

Brackets: 215-AB40

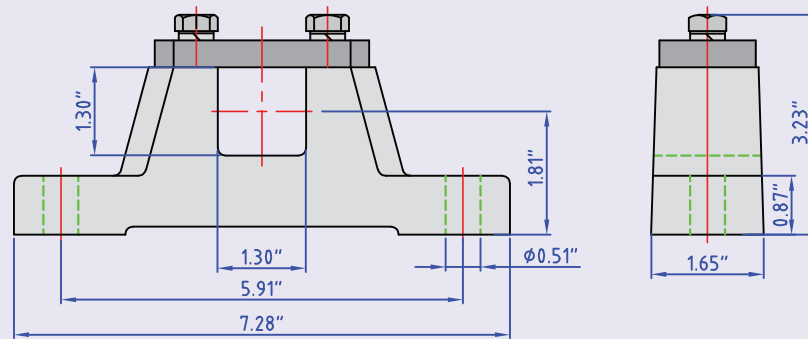

PES Cable Option:

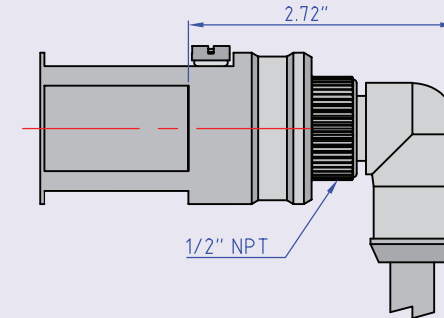

TM215B40 Drum Motor

7.5 HP

V (ft/min) M/G	1117 2/S2	912 2/S2	821 2/S2	657 2/S2	583 2/S2	547 2/S3	465 2/S2	403 2/S2	358 2/S2	335 2/S2	310 2/S2	255 2/S2	228 2/S3
Belt Pull (lbf)	198	243	270	337	285	405	476	549	618	662	715	651	972
Drum RPM	504	412	371	297	263	247	210	182	162	151	140	115	103

5.0 HP

V (ft/min) M/G	1117 2/S2	912 2/S2	821 2/S2	657 2/S2	583 2/S2	547 2/S3	465 2/S2	403 2/S2	358 2/S2	335 2/S2	310 2/S2	275 4/S3	255 2/S2	238 2/S2	234 4/S2
Belt Pull (lbf)	145	178	198	247	278	297	349	402	453	485	524	521	636	681	613
Drum RPM	503	411	370	296	263	246	209	182	161	151	140	124	115	107	105

V (ft/min) M/G	228 2/S3	221 2/S2	202 4/S3	198 2/S3	162 2/S3	114 4/S3
Belt Pull (lbf)	712	552	709	821	1000	1250
Drum RPM	103	100	91	89	73	51

3.0 HP

V (ft/min) M/G	679 4/S2	559 4/S2	483 4/S2	398 4/S2	325 4/S2	293 4/S2	233 4/S2	234 4/S2	208 4/S2	202 4/S2	166 4/S2	155 4/S2	144 4/S2	128 4/S2	119 4/S2
Belt Pull (lbf)	130	158	183	222	272	302	379	377	425	437	533	569	614	692	741
Drum RPM	307	253	218	180	147	132	105	106	94	91	75	70	65	58	54

V (ft/min) M/G	114 4/S3	99 4/S3	81 4/S3	70 4/S3	63 4/S3
Belt Pull (lbf)	774	893	1087	1254	1412
Drum RPM	52	45	37	32	28

2.0 HP

V (ft/min) M/G	685 4/S2	564 4/S2	488 4/S2	402 4/S2	376 6/S2	328 4/S2	295 4/S2	236 4/S2	210 4/S2	204 4/S2	197 6/S2	185 4/S2	167 4/S2	157 6/S2	145 4/S2
Belt Pull (lbf)	82	99	115	140	164	171	190	237	267	275	314	304	335	394	386
Drum RPM	309	255	220	181	170	148	133	107	95	92	89	83	76	71	65

V (ft/min) M/G	136 6/S2	129 4/S2	120 4/S2	111 4/S2	104 6/S2	97 6/S2	86 6/S2	77 6/S3	71 4/S3	67 6/S3	55 6/S3	47 6/S3
Belt Pull (lbf)	455	435	466	503	592	639	719	805	789	928	1131	1304
Drum RPM	61	58	54	50	47	44	39	35	32	30	25	21

V = Belt Speed (ft/min)

M/G = Motor/Gear Reducer Configuration
(at rated horsepower)High Speed
Low Torque

Low Speed
High Torque

TM215B50 Drum Motor (matching Idler KT215B50**)

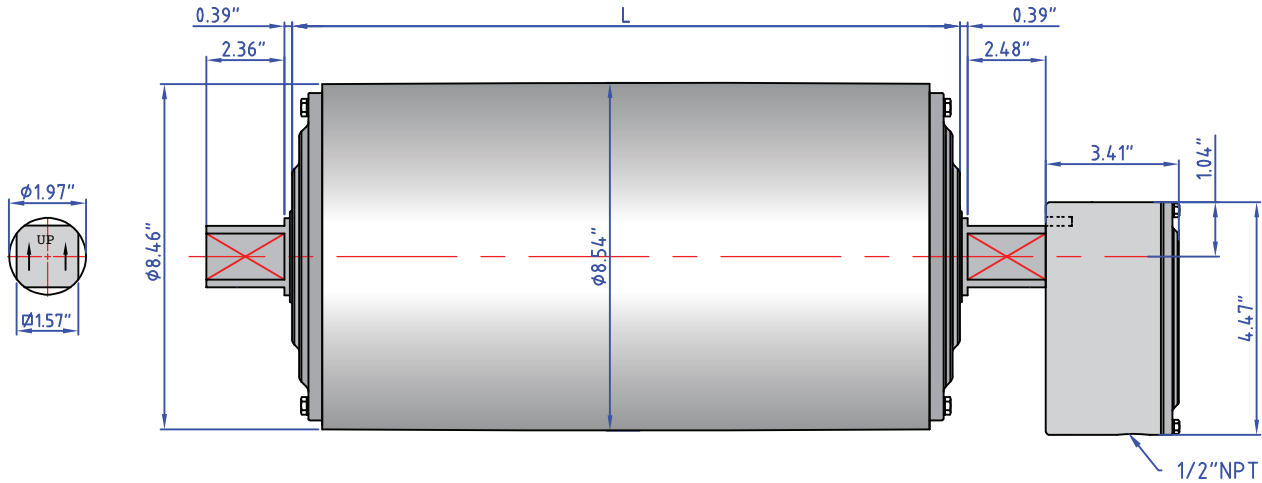

NOTE: Junction Box **does not rotate**.
Power entry at 6 o'clock position.

Standard drum motor face widths* (L) in inches:

19.69	21.65	23.62	25.59	27.56	29.53	31.50	33.46	35.43
37.40	39.37	41.34	43.31	45.28	47.24			

*Some face widths are not available in all horsepower. For minimum available face widths refer to page 21.

**Idler dimensions are identical to the drum motor with no junction box.

Brackets: 215-AB50

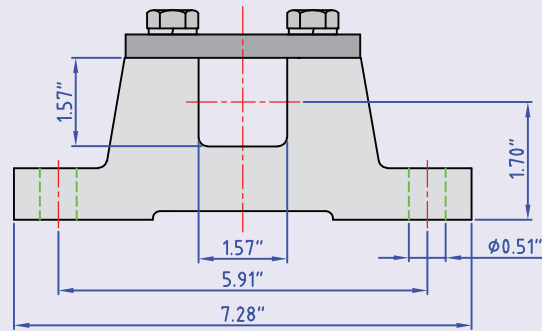

PES Cable Option:

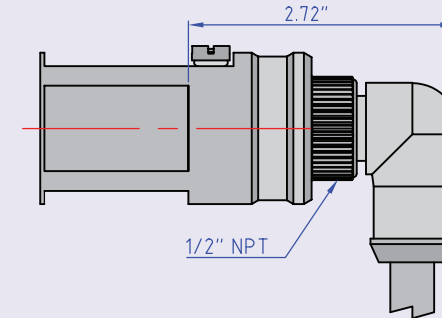

TM215B50 Drum Motor

7.5 HP

V (ft/min) M/G	142 2/PL2	129 2/PL2
Belt Pull (lbf)	1559	1714
Drum RPM	64	58

5.0 HP

V (ft/min) M/G	142 2/PL2	129 2/PL2	71 4/PL2	65 4/PL2
Belt Pull (lbf)	1275	1403	2317	2531
Drum RPM	64	58	32	29

3.0 HP

V (ft/min) M/G	71 4/PL2	65 4/PL2	47 6/PL2	43 6/PL2
Belt Pull (lbf)	1241	1365	1887	2075
Drum RPM	32	29	21	19

2.0 HP

V (ft/min) M/G	48 6/PL2	44 6/PL2
Belt Pull (lbf)	1291	1419
Drum RPM	22	20

V = Belt Speed (ft/min)

M/G = Motor/Gear Reducer Configuration
(at rated horsepower)

High Speed
Low Torque



Low Speed
High Torque

	DRUM PROFILE*												XP SLEEVE PROFILE*			
	TM100		TM113		TM127		TM138		TM160		TM215		TM127		TM160	
	No. of Teeth	Pitch Dia. (inches)	No. of Teeth	Pitch Dia. (inches)	No. of Teeth	Pitch Dia. (inches)	No. of Teeth	Pitch Dia. (inches)	No. of Teeth	Pitch Dia. (inches)	No. of Teeth	Pitch Dia. (inches)	No. of Teeth	Pitch Dia. (inches)	No. of Teeth	Pitch Dia. (inches)
INTRALOX Belt																
Series 100							19	6.14					19	6.14		
Series 400							10	6.49	12	7.75	15	9.64	10	6.49	12	7.75
Series 560			48	4.82												
Series 800			9	5.89			10	6.52	12	7.79	15	9.69	10	6.52	12	7.79
Series 900	13	4.48	15	5.16	17	5.83							17	5.83		
Series 1000	23	4.46					30	5.81					30	5.81		
Series 1100	24	4.65	26	5.03	30	5.81	32	6.19					32	6.19		
Series 1400							19	6.14	24	7.74			19	6.14	24	7.74
Series 1500			32	5.14			37	5.98								
Series 1600	14	4.63	16	5.28	18	5.93	19	6.26	22	7.24	29	9.53	19	6.26	23	7.56
Series 2200					13	6.31							14	6.79		
Series 2400			17	5.47	19	6.12	20	6.42	23	7.38	30	9.62	20	6.42	24	7.70
Series 3000					11	7.1										
Series 4400							10	6.50								
ThermoDrive 8026 Endless			15	4.94			18	5.92	21	6.91			18	5.92	22	7.24
ThermoDrive 8050 Endless			8	5.13	9	5.77	10	6.41	12	7.70	15	9.62	10	6.41	12	7.70
Series 8140																
VOLTA Belt																
Super Drive- 3mm thick belt	10	4.90							13	6.41	17	8.49	13	6.41	16	7.99
Super Drive- 3mm thick belt									14	6.91			14	6.91		
Super Drive- 4mm thick belt									13	6.37	17	8.56	13	6.37	16	8.05
Super Drive- 4mm thick belt									14	7.02			14	7.02		
Mini Super Drive- 2.5mm thick belt	15	4.71					19	5.99	20	6.31			19	5.99		
Dual Drive							10	6.14	12	7.39	15	9.22	10	6.14	12	7.39
Mini Dual Drive	14	4.39			18	5.67	19	5.99	22	6.95						

*Profile is machined directly onto the stainless steel drum (SSV Drum Motor) or machined directly onto the stainless steel removeable sleeve (SSV-XP Drum Motor).

NOTE: Heavy-Duty Edge (HDE), Clean Release, Activated Roller Belt (ARB), Tight Turning Radius Belt, and ThermoLace are available upon request.
Contact VDG Customer Service for belt series not listed.

	DRUM PROFILE*												XP SLEEVE PROFILE*			
	TM100		TM113		TM127		TM138		TM160		TM215		TM127		SSV-XP TM160	
	No. of Teeth	Pitch Dia. (inches)	No. of Teeth	Pitch Dia. (inches)	No. of Teeth	Pitch Dia. (inches)	No. of Teeth	Pitch Dia. (inches)	No. of Teeth	Pitch Dia. (inches)	No. of Teeth	Pitch Dia. (inches)	No. of Teeth	Pitch Dia. (inches)	No.# of Teeth	Pitch Dia. (inches)
HABASIT Belt																
Clean Drive 25							18	6.06					18	6.06		
Clean Drive 50							10	6.35	12	7.60			10	6.35	12	7.60
Clean Drive M40									13	6.41	17	8.49				
M1200							36	5.90					36	5.90		
M2500			16	5.20	18	5.77							18	5.77		
M3800							13	6.36					13	6.36		
M5000							10	6.50	12	7.76	15	9.66	10	6.50	12	7.76
HDU620 GP Belt Material							10	6.50	12	7.70			10	6.50	12	7.70
SM605																
Gates Belt																
PC20							10	6.20					10	6.20		
Rexnord Belt																
Pactitan							42	5.71								
Wire Belt Company																
Compact Grid 10mm					21											
Compact Grid 10mm with Flights					22											
Eye Flex	Number of Teeth Depends on Belt Number															
Flat Flex																

*Profile is machined directly onto the stainless steel drum (SSV Drum Motor) or machined directly onto the stainless steel removeable sleeve (SSV-XP Drum Motor).

NOTE: Heavy-Duty Edge (HDE), Clean Release, Activated Roller Belt (ARB), Tight Turning Radius Belt, and ThermoLace are available upon request. Contact VDG Customer Service for belt series not listed.

TM100B25

HP	0.25			0.16						0.14		
Motor/Gear Reducer	4/S2	4/PL2	4/PL3	4/S2	4/PL2	4/PL3	6/S2	6/PL2	6/PL3	4/S2	4/PL2	4/PL3
Min. Face Width (L)	12.20	12.20	14.17	12.20	12.20	14.17	12.20	12.20	14.17	10.24	10.24	12.20

TM113B25

HP	0.75	0.5			0.34					0.25		
Motor/Gear Reducer	2/S2	2/S2	4/S2	4/PL2	2/S2	4/S2	4/PL2	6/S2	6/PL2	4/S2	4/PL2	4/PL3
Min. Face Width (L)	12.20	12.20	14.17	14.17	10.24	12.20	12.20	14.17	14.17	12.20	12.20	14.17

TM127B30 / TM138B30

HP	1.5	1.0			0.75					0.5			0.34		0.25		
Motor/Gear Reducer	4/S2	2/S2	4/S2	4/PL2	2/S2	6/S2	4/S2	4/S3	4/PL2	6/S2	4/S2	4/S3	4/PL2	6/PL2	4/S2	4/S3	4/PL3
Min. Face Width (L)	14.76	13.78	13.78	15.75	12.80	13.78	12.80	13.78	14.76	12.80	12.80	13.78	14.76	14.76	11.81	12.80	15.75



TM160B40

HP	3.0	2.0				1.5	1.0			0.75		
Motor/Gear Reducer	2/S2	2/S2	4/S2	2/PL2	4/PL2	4/S2	4/S2	4/S3	4/PL2	4/S2	4/S3	4/PL2
Min. Face Width (L)	16.73	15.75	17.72	17.72	17.72	15.75	15.75	16.73	17.72	15.75	16.73	17.72

TM215B40 / TM215B50

HP	7.5			5.0						3.0				2.0				
Motor/Gear Reducer	2/S2	2/S3	2/PL2	2/S2	2/S3	2/PL2	4/S2	4/S3	4/PL2	4/S2	4/S3	4/PL2	6/PL2	4/S2	6/S2	4/S3	6/S3	6/PL2
Min. Face Width (L)	21.65	23.62	23.62	21.65	23.62	23.62	21.65	23.62	23.62	19.69	21.65	23.62	23.62	19.69	21.65	21.65	23.62	23.62

BELT PULL CALCULATIONS

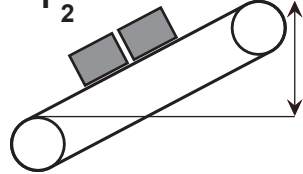
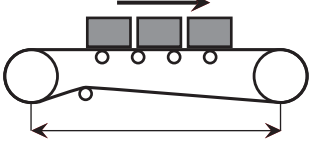
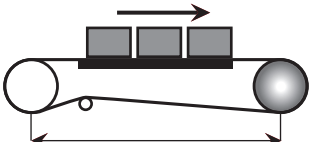
CONVEYING SYSTEM	F_0  Force without Load	F_1  Force to Convey Materials Horizontally	F_2  Force to Convey Materials on Incline	<p style="text-align: center;">BELT PULL (BP) $BP = (F_0 + F_1 + F_2)$</p> <p>F = Force (lbs.) P = Belt weight (lbs./linear ft.) Q = Weight of rotating parts in pounds per foot of length of belt conveyor R = Weight in pounds of conveyor product per foot of belt conveyor length C = Co-efficient of friction between conveyor belt and top slider bed L = Center to center length (feet) H = Height (feet)</p>
Roller Bed Conveyor R 	$F_0 = 0.04 (2P + Q) L$	$F_1 = 0.04 \times R \times L$	$F_2 = R \times H$	
Slider Bed Conveyor R 	$F_0 = 1.1 \times P \times L \times C$	$F_1 = 1.1 \times R \times L \times C$	$F_2 = R \times H$	

Calculations:

NOTES



A series of horizontal lines for taking notes, arranged in a grid-like pattern across the page.



Canada



USA



Netherlands

VDG (Van der Graaf) has provided conveyor drive solutions to the material handling and processing industries for over half a century. VDG continues as the leader in the design and manufacturing of drum motors by consistently investing in research and development and utilizing cutting-edge production technology and automation. With in-house precision manufacturing, VDG ensures product quality, fast delivery, and superior customer support.

VDG adheres to high quality standards and a simple principle: design a superior product to meet customer needs in a changing marketplace.



1-888-326-1476 | info@vandergraaf.com | www.vandergraaf.com

